 <i>Good Display</i>	E paper IC Specifications	SPEC NO	
	IL0376F	REV NO	

Good Display Specifications

Prepared: AiMing Wei
Checked: YongCheng Jian
Approved: Boris Ren
Issue Date: 2016.4.7



Dalian Good Display Co., Ltd.

No.17 Gonghua Street, Shahekou District, Dalian 116021 China
Tel: +86-411-84619565 Fax: +86-411-84619585
E-mail: info@good-display.com
Website: www.good-display.com

Table of Content

INTRODUCTION 3

MAIN APPLICATIONS..... 3

FEATURE HIGHLIGHTS 3

BLOCK DIAGRAM..... 4

PIN DESCRIPTION 6

COMMAND TABLE..... 8

COMMAND DESCRIPTION..... 10

HOST INTERFACES 22

POWER MANAGEMENT..... 26

ABSOLUTE MAXIMUM RATINGS 31

DC CHARACTERISTICS 32

AC CHARACTERISTICS 33

PHYSICAL DIMENSIONS..... 35

ALIGNMENT MARK INFORMATION 36

PAD COORDINATES 37

TRAY INFORMATION..... 44

INTRODUCTION

This driver is an all-in-one driver with timing controller for ESL. Its output is of 2-bit white/black and 1-bit red resolution per pixel. The timing controller provides control signals for the source driver and gate drivers.

The DC-DC controller allows it to generate the source output voltage VDPS/VDNS (+/-2.4V~+/-8V, +/-15V). The chip also includes an output buffer for the supply of the COM electrode (VCOMAC or VCOMDC). The system is configurable through a 3-wire/4-wire (SPI) serial interface.

MAIN APPLICATIONS

- E-tag application

FEATURE HIGHLIGHTS

- System-on-chip (SOC) for ESL
- Timing controller supports several all-resolutions
- Preselectable resolution (SourceGate):
 - 94x230
 - 94x252
 - 128x296
 - 200x300
- Built-in Frame memory (Max.): 300x200x3bit
- Support LUT1 (VCOM1, White, Black, Gray1, Gray2)
- Support LUT2 (VCOM2, Red0, Red1)
- Source Driver with 2-bit white/black resolution and 1-bit red resolution
 - 200 channels
 - Output dynamic range: VDNS, 0, VDPS
 - Output deviation: 0.2 V
 - Left and Right shift capability
- Gate Driver:
 - 300 channel outputs
 - Output voltage VDNG+40
 - Up and Down scan capability
- 3-wire/4-wire (SPI) serial interface
- DC-DC controller for generating the analog power supply
- COM electrode (VCOM AC) level
- Built-in temperature sensor
- Digital supply voltage: 2.3~ 3.6V
- Operating frequency: 20MHz (max)
- COG Package
- COM/SEG bump information
 - Bump pitch: 42 μM
 - Bump gap: 24 $\mu\text{M} \pm 3\mu\text{M}$
 - Bump surface: 1350 μM^2

BLOCK DIAGRAM

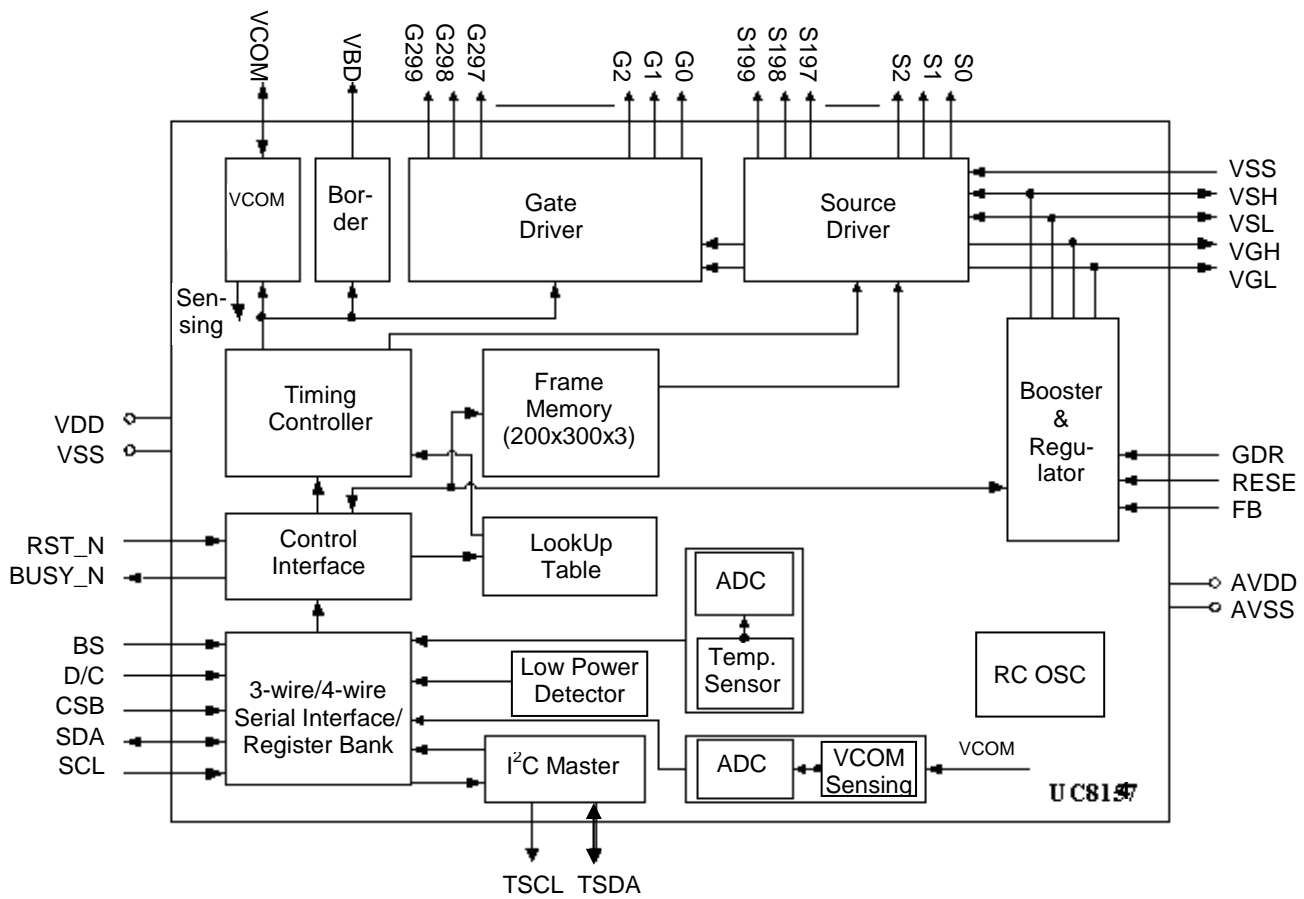

Pin (Pad) Name	Pin Count	Type	Description
OUTPUT DRIVER			
S[0..199] (S<0>~S<199>)	200	O	Source driver output signals.
G[0..299] (G<0>~G<299>)	300	O	Gate driver output signals.
VBD (VBD<1>~VBD<2>)	2	O	Border output pins. It outputs black WF.
CL	1	I/O	Clock pin for cascade mode. In single-chip mode, keep CL open. In cascade mode, the CL pin of the slave chip should be connected to the CL pin of the master chip.
MS	1	I	Master/Slave selection for cascade mode. Low: Slave, High: Master In single-chip mode, MS should be connect to VDD.
VSYNC	1	I/O	Vsync pin for cascade mode. In single-chip mode, VSYNC should be connected to GND or VDD. In cascade mode, VSYNC pin of slave chip shoulde be connected to VSYNC pin of master chip.
VCOM GENERATOR			
VCOM	16	O	VCOM output. It has the following voltage states: (VDPS+VCM_DC) V, (VCM_DC) V, (VDNS+VCM_DC) V, Floating
POWER CIRCUIT			
GDR	8	O	N-MOS gate control
RESE	2	P	Current sense input for control loop.
FB	2	P	(Keep Open.)
VGH	20	C	Positive Gate voltage.
VGL	24	C	Negative Gate voltage.
VSH	10	C	Positive Source voltage.
VSL	10	C	Negative Source voltage.
MISC. PINS			
NC	40		Not Connected.
Dummy	26		Dummy pins.

COMMAND TABLE

[W/R]: 0: Write Cycle 1: Read Cycle **[C/D]**: 0: Command / 1: Data **[D7~D0]**: -: Don't Care #: Valid Data

#	Command	W/R	C/D	D7	D6	D5	D4	D3	D2	D1	D0	Registers	Default	
1	Panel Setting (PSR)	0	0	0	0	0	0	0	0	0	0	RES, KW/R, UD, SHL, SHD_N, RST_N	00h 0Fh	
2	Power Setting (PWR)	0	0	0	0	0	0	0	0	0	1	RVSHLS, VDS_EN, VDG_EN VGHL_LV VDPS_LV VDNS_LV	01h 03h 00h 08h 08h	
		0	1	--	--	--	--	--	--	#	#		#	#
		0	1	--	--	--	#	#	#	#	#		#	#
		0	1	--	--	--	#	#	#	#	#		#	#
3	Power OFF (POF)	0	0	0	0	0	0	0	0	1	0		02h	
4	Power OFF Sequence Setting (PFS)	0	0	0	0	0	0	0	0	1	1		03h	
		0	1	--	--	#	#	--	--	--	--	--	T_VDS_OFF	00h
5	Power ON (PON)	0	0	0	0	0	0	0	1	0	0		04h	
6	Power ON Measure (PMES)	0	0	0	0	0	0	0	1	0	1		05h	
7	Booster Soft Start (BTST)	0	0	0	0	0	0	0	1	1	0	BT_PHA[6:0] BT_PHB[6:0] BT_PHC[4:0]	06h 0Fh 0Eh 0Dh	
		0	1	--	#	#	#	#	#	#	#		#	
		0	1	--	#	#	#	#	#	#	#		#	
		0	1	--	--	--	#	#	#	#	#		#	
8	Display Start Transmission 1 (DTM1) (x-byte command)	0	0	0	0	0	1	0	0	0	0	KPixel1, KPixel2, KPixel3, KPixel4 : KPixel(n-1), KPixel(n)	10h 00h : 00h	
		0	1	#	#	#	#	#	#	#	#		#	
		0	1	--	--	--	--	--	--	--	--		--	
		0	1	#	#	#	#	#	#	#	#		#	
9	Data Stop (DSP)	0	0	0	0	0	1	0	0	0	1	data_flag	11h --	
		1	1	#	--	--	--	--	--	--	--		--	
10	Display Refresh (DRF)	0	0	0	0	0	1	0	0	1	0		12h	
11	Display Start transmission 2 (DTM2) (y-byte command)	0	0	0	0	0	1	0	0	1	1	RPixel1, RPixel2, RPixel3, RPixel4 : RPixel(n-1), RPixel(n)	13h 00h : 00h	
		0	1	#	#	#	#	#	#	#	#		#	
		0	1	--	--	--	--	--	--	--	--		--	
		0	1	#	#	--	--	--	--	--	--		--	
12	Vcom1 LUT (LUTC1) (16-byte command, bytes 2~4 repeated 5 times)	0	0	0	0	1	0	0	0	0	0		20h 00h 00h 00h	
		0	1	#	#	#	#	#	#	#	#		#	
		0	1	#	#	#	#	#	#	#	#		#	
		0	1	#	#	#	#	#	#	#	#		#	
13	White LUT (LUTW) (16-byte command, bytes 2~4 repeated 5 times)	0	0	0	0	1	0	0	0	0	1		21h 00h 00h 00h	
		0	1	#	#	#	#	#	#	#	#		#	
		0	1	#	#	#	#	#	#	#	#		#	
		0	1	#	#	#	#	#	#	#	#		#	
14	Black LUT (LUTB) (16-byte command, bytes 2~4 repeated 5 times)	0	0	0	0	1	0	0	0	1	0		22h 00h 00h 00h	
		0	1	#	#	#	#	#	#	#	#		#	
		0	1	#	#	#	#	#	#	#	#		#	
		0	1	#	#	#	#	#	#	#	#		#	
15	Gray1 LUT (LUTG1) (16-byte command, bytes 2~4 repeated 5 times)	0	0	0	0	1	0	0	0	1	1		23h 00h 00h 00h	
		0	1	#	#	#	#	#	#	#	#		#	
		0	1	#	#	#	#	#	#	#	#		#	
		0	1	#	#	#	#	#	#	#	#		#	
16	Gray2 LUT (LUTG2) (16-byte command, bytes 2~4 repeated 5 times)	0	0	0	0	1	0	0	1	0	0		24h 00h 00h 00h	
		0	1	#	#	#	#	#	#	#	#		#	
		0	1	#	#	#	#	#	#	#	#		#	
		0	1	#	#	#	#	#	#	#	#		#	
17	Vcom2 LUT (LUTC2) (16-byte command, bytes 2~4 repeated 5 times)	0	0	0	0	1	0	0	1	0	1		25h 00h 00h 00h	
		0	1	#	#	#	#	#	#	#	#		#	
		0	1	#	#	#	#	#	#	#	#		#	
		0	1	#	#	#	#	#	#	#	#		#	
18	Red0 LUT (LUTR0) (16-byte command, bytes 2~4 repeated 5 times)	0	0	0	0	1	0	0	1	1	0		26h 00h 00h 00h	
		0	1	#	#	#	#	#	#	#	#		#	
		0	1	#	#	#	#	#	#	#	#		#	
		0	1	#	#	#	#	#	#	#	#		#	

#	Command	W/R	C/D	D7	D6	D5	D4	D3	D2	D1	D0	Registers	Default
19	Red1 LUT (LUTR1) (16-byte command, bytes 2~4 repeated 5 times)	0	0	0	0	1	0	0	1	1	1		27h
		0	1	#	#	#	#	#	#	#	#		00h
		0	1	#	#	#	#	#	#	#	#		00h
		0	1	#	#	#	#	#	#	#	#		00h
20	PLL control (PLL)	0	0	0	0	1	1	0	0	0	0	M, N	30h
		0	1	--	--	#	#	#	#	#	#		2Ah
21	Temperature Sensor Calibration (TSC)	0	0	0	1	0	0	0	0	0	0	TSE[D10:D0] / TS[3:0]	40h
		1	1	#	#	#	#	#	#	#	#		00h
		1	1	#	#	#	--	--	--	--	--		00h
22	Temperature Sensor Selection (TSE)	0	0	0	1	0	0	0	0	0	1	TSE	41h
		0	1	#	--	--	--	--	--	--	--		00h
23	Temperature Sensor Write (TSW)	0	0	0	1	0	0	0	0	1	0	WATTR[7:0] WMSB[7:0] WLSB[7:0]	42h
		0	1	#	#	#	#	#	#	#	#		00h
		0	1	#	#	#	#	#	#	#	#		00h
		0	1	#	#	#	#	#	#	#	#		00h
24	Temperature Sensor Read (TSR)	0	0	0	1	0	0	0	0	1	1	RMSB[7:0] RLSB[7:0]	43h
		1	1	#	#	#	#	#	#	#	#		00h
		1	1	#	#	#	#	#	#	#	#		00h
25	Vcom and data interval setting (CDI)	0	0	0	1	0	1	0	0	0	0	SD_BDZH, DDX, CDI	50h
		0	1	--	--	#	#	#	#	#	#		17h
26	Lower Power Detection (LPD)	0	0	0	1	0	1	0	0	0	1	LPD	51h
		1	1	--	--	--	--	--	--	--	#		--
27	TCON setting (TCON)	0	0	0	1	1	0	0	0	0	0	S2G, G2S	60h
		0	1	#	#	#	#	#	#	#	#		22h
28	Resolution setting (TRES)	0	0	0	1	1	0	0	0	0	1	HRES VRES[8:0]	61h
		0	1	#	#	#	#	#	#	#	#		00h
		0	1	--	--	--	--	--	--	--	#		00h
		0	1	#	#	#	#	#	#	#	#		00h
29	Revision (REV)	0	0	0	1	1	1	0	0	0	0		70h
		1	1	0	0	0	0	0	0	0	0		00h
30	Get Status (FLG)	0	0	0	1	1	1	0	0	0	1	I2C_ERR, I2C_BUSYN, data_flag, PON, POF, BUSY_N	71h
		1	1	--	--	--	--	--	--	#	#		02h
31	Auto Measurement Vcom	0	0	1	0	0	0	0	0	0	0	AMVT, AMV, AMVE	80h
		0	1	--	--	#	#	--	--	#	#		10h
32	Read Vcom Value(VV)	0	0	1	0	0	0	0	0	0	1	VV	81h
		1	1	--	--	#	#	#	#	#	#		00h
33	VCM_DC Setting (VDCS)	0	0	1	0	0	0	0	0	1	0	VDCS	82h
		0	1	--	--	#	#	#	#	#	#		00h

- Note:**
- (1) All other register addresses are invalid or reserved by UltraChip, and should NOT be used.
 - (2) Any bits shown here as 0 must be written with a 0. All unused bits should also be set to zero. Device malfunction may occur if this is not done.
 - (3) Commands are processed on the 'stop' condition of the interface.
 - (4) Registers marked 'W/R' can be read, but the contents are written when the SPI command completes – so the contents can be read and altered. The user can subsequently write the register to restore the contents following an SPI read.
 - (5) All registers are accessible, (i.e., Host can send command/data to driver), only when BUSY_N = 1; except R01h (PWR), R03h (PFS), R04h (PON), R05h (PMES), R06h(BTST), R51h (LPD), and R71h(FLG), which are accessible either when BUSY_N=0 or 1.

COMMAND DESCRIPTION

W/R: 0: Write Cycle / 1: Read Cycle **C/D**: 0: Command / 1: Data **D7-D0**: -: Don't Care

(1) PANEL SETTING (PSR) (REGISTER: R00H)

Action	W/R	C/D	D7	D6	D5	D4	D3	D2	D1	D0
Setting the panel	0	0	0	0	0	0	0	0	0	0
	0	1	RES1	RES0	--	KWR	UD	SHL	SHD_N	RST_N

RES[1:0]: Display Resolution setting (source x gate)

00b: 94x230 (Default) Active source channels: S0 ~ S93. Active gate channels: G0 ~ G229.
01b: 94x252 Active source channels: S0 ~ S93. Active gate channels: G0 ~ G251.
10b: 128x296 Active source channels: S0 ~ S127. Active gate channels: G0 ~ G295.
11b: 200x300 Active source channels: S0 ~ S199. Active gate channels: G0 ~ G299.

KWR: KW/R function

0: Pixel with K/W/Red. Will run both LU1 and LU2. (Default)
1: Pixel with K/W. Will run LU1 only.

UD: **0: Scan down.** First line to Last line: Gn-1 → Gn-2 → Gn-3 → ... → G0

1: Scan up. (Default) First line to Last line: G0 → G1 → G2 → ... → Gn-1

SHL: **0: Shift left.** First data to Last data: Sn-1 → Sn-2 → Sn-3 → ... → S0

1: Shift right. (Default) First data to Last data: S0 → S1 → S2 → ... → Sn-1

SHD_N: **0: DC-DC converter will be turned OFF**
1: DC-DC converter will be turned ON (Default)

When SHD_N become LOW, charge pump will be turned OFF, register and SRAM data will keep until VDD OFF, and SD output and VCOM will remain previous condition. SHD_N may have two conditions: 0v or floating.

RST_N: **0: The controller is reset. Reset all registers to default value.**
1: No effect (Default)

When RST_N become LOW, the driver will be reset, all registers will be reset to their default value. All driver functions will be disabled. SD output and VCOM will base on previous condition. It may have two conditions: 0v or floating.

This command can be active only when BUSY_N = "1".

(2) POWER SETTING (PWR) (R01H)

Action	W/R	C/D	D7	D6	D5	D4	D3	D2	D1	D0
Selecting Internal/External Power	0	0	0	0	0	0	0	0	0	1
	0	1	-	-	-	-	RVSHLS	RVSHLS	VDS_EN	VDG_EN
	0	1	-	-	-	-	-	-	VGHL_LV[1:0]	
	0	1	-	-	-	VDPS_LV[4:0]				
	0	1	-	-	-	VDNS_LV[4:0]				

RVSHLS[1:0]: Source power selection

RVSHLS[1:0]	VSH	VSL
00	+2.4 ~ +8.0V	-2.4 ~ -8.0V
01	+2.4 ~ +8.0V	-15V
10	+15V	-2.4 ~ -8.0V
11	+15V	-15V

VDS_EN: Source power selection
 0 : External source power from VDH/VDL pins
 1 : Internal DC/DC function for generating VDH/VDL

VDG_EN: Gate power selection
 0 : External gate power from VGH/VGL pins
 1 : Internal DC/DC function for generating VGH/VGL

VGHL_LV[1:0]: VGHL_LVL / VDNG_LVL power selection.

VGHL_LV	VGHL_LVL power
00 (DEFAULT)	VGH=20V, VGL= -19.3V
01	VGH=19V, VGL= -18.3V
10	VGH=18V, VGL= -17.3V
11	VGH=17V, VGL= -16.3V

VDPS_LV[4:0]: Internal VDPS power selection for Red LUT. (Default value: 01000b)

VDPS_LV	VDPS	VDPS_LV	VDPS	VDPS_LV	VDPS	VDPS_LV	VDPS
00000	2.4 V	01000	4.0 V	10000	5.6 V	11000	7.2 V
00001	2.6 V	01001	4.2 V	10001	5.8 V	11001	7.4 V
00010	2.8 V	01010	4.4 V	10010	6.0 V	11010	7.6 V
00011	3.0 V	01011	4.6 V	10011	6.2 V	11011	7.8 V
00100	3.2 V	01100	4.8 V	10100	6.4 V	11100	8.0 V
00101	3.4 V	01101	5.0 V	10101	6.6 V	(others)	4.0 V
00110	3.6 V	01110	5.2 V	10110	6.8 V		
00111	3.8 V	01111	5.4 V	10111	7.0 V		

VDNS_LV[4:0]: Internal VDNS power selection for Red LUT. (Default value: 01000b)

VDNS_LV	VDNS	VDNS_LV	VDNS	VDNS_LV	VDNS	VDNS_LV	VDNS
00000	-2.4 V	01000	-4.0 V	10000	-5.6 V	11000	-7.2 V
00001	-2.6 V	01001	-4.2 V	10001	-5.8 V	11001	-7.4 V
00010	-2.6 V	01010	-4.4 V	10010	-6.0 V	11010	-7.6 V
00011	-3.0 V	01011	-4.6 V	10011	-6.2 V	11011	-7.8 V
00100	-3.2 V	01100	-4.8 V	10100	-6.4 V	11100	-8.0 V
00101	-3.4 V	01101	-5.0 V	10101	-6.6 V	(others)	-4.0 V
00110	-3.6 V	01110	-5.2 V	10110	-6.8 V		
00111	-3.8 V	01111	-5.4 V	10111	-7.0 V		

This command can be active only when BUSY_N = "1".

(3) POWER OFF (POF) (R02H)

Action	W/R	C/D	D7	D6	D5	D4	D3	D2	D1	D0
Turning OFF the power	0	0	0	0	0	0	0	0	1	0

After the Power Off command, driver will power off based on the Power Off Sequence, BUSY_N will become "0". This command will turn off charge pump, T-con, source driver, gate driver, VCOM, and temperature sensor, but register data will be kept until VDD becomes OFF.

SD output and Vcom will base on previous condition. It may have 2 conditions: 0V or floating.

This command can be active only when BUSY_N = "1".

(4) POWER OFF SEQUENCE SETTING (PFS) (R03H)

Action	W/R	C/D	D7	D6	D5	D4	D3	D2	D1	D0
Setting Power OFF sequence	0	0	0	0	0	0	0	0	1	0
	0	1	-	-	T_VDS_OFF[1:0]		-		-	

T_VDS_OFF[1:0]: Power OFF Sequence of VDPS and VDNS.

00b: 1 frame (Default)

01b: 2 frames

10b: 3 frames

11b: 4 frame

This command can be active only when BUSY_N = "1".

(5) POWER ON (PON) (REGISTER: R04H)

Action	W/R	C/D	D7	D6	D5	D4	D3	D2	D1	D0
Turning ON the power	0	0	0	0	0	0	0	1	0	0

After the Power ON command, the driver will be powered ON following the Power ON Sequence. After the Power ON command and all power sequence are ready, the BUSY_N signal will become "1". Refer to the Power ON Sequence section.

(6) POWER ON MEASURE (PMES) (R05H)

Action	W/R	C/D	D7	D6	D5	D4	D3	D2	D1	D0
Turning ON the power	0	0	0	0	0	0	0	1	0	1

This command releases BUSY_N restriction for command TSC and command LPD until next Power Off.

(7) BOOSTER SOFT START (BTST) (R06H)

Action	W/R	C/D	D7	D6	D5	D4	D3	D2	D1	D0
Starting data transmission	0	0	0	0	0	0	0	1	1	0
	0	1	-	BTPHA6	BTPHA5	BTPHA4	BTPHA3	BTPHA2	BTPHA1	BTPHA0
	0	1	-	BTPHB6	BTPHB5	BTPHB4	BTPHB3	BTPHB2	BTPHB1	BTPHB0
	0	1	-	-	-	BTPHC4	BTPHC3	BTPHC2	BTPHC1	BTPHC0

BTPHA[6:5]: Soft start period of phase A. **00b: 10mS** 01b: 20mS 10b: 30mS 11b: 40mS

BTPHA[4:3]: Driving strength of phase A

00b: strength 1 **01b: strength 2** 10b: strength 3 11b: strength 4 (strongest)

BTPHA[2:0]: Minimum OFF time setting of GDR in phase B

000b: 0.27uS 001b: 0.34uS 010b: 0.40uS 011b: 0.54uS
 100b: 0.80uS 101b: 1.54uS 110b: 3.34uS **111b: 6.58uS**

BTPHB[6:5]: Soft start period of phase B. **00b: 10mS** 01b: 20mS 10b: 30mS 11b: 40mS

BTPHB[4:3]: Driving strength of phase B

00b: strength 1 **01b: strength 2** 10b: strength 3 11b: strength 4 (strongest)

BTPHB[2:0]: Minimum OFF time setting of GDR in phase B

000b: 0.27uS 001b: 0.34uS 010b: 0.40uS 011b: 0.54uS
 100b: 0.80uS 101b: 1.54uS **110b: 3.34uS** 111b: 6.58uS

BTPHC[4:3]: Driving strength of phase C

00b: strength 1 **01b: strength 2** 10b: strength 3 11b: strength 4 (strongest)

BTPHC[2:0]: Minimum OFF time setting of GDR in phase C

000b: 0.27uS 001b: 0.34uS **010b: 0.40uS** 011b: 0.54uS
 100b: 0.80uS 101b: 1.54uS 110b: 3.34uS 111b: 6.58uS

(8) DATA START TRANSMISSION 1 (DTM1) (R10H)

Action	W/R	C/D	D7	D6	D5	D4	D3	D2	D1	D0
Starting data transmission	0	0	0	0	0	1	0	0	0	0
	0	1	kpixel1[1:0]		kpixel2[1:0]		kpixel3[1:0]		kpixel4[1:0]	
	0	1	
	0	1	kpixel(n-1)[1:0]		kpixel(n)[1:0]		-	-	-	-

This command starts transmitting data and write them into SRAM. To complete data transmission, command DSP (Data transmission Stop) must be issued. Then the chip will start to send data/VCOM for panel.

This command can be active only when BUSY_N = "1".

KPixel(x)[1:0]:

DDX	KPixel (x) [1:0]	LUT
0	00	White
	01	Gray2
	10	Gray1
	11	Black
1	00	Black
	01	Gray1
	10	Gray2
	11	White

(9) DATA STOP (DSP) (R11H)

Action	W/R	C/D	D7	D6	D5	D4	D3	D2	D1	D0
Stopping data transmission	0	0	0	0	0	1	0	0	0	1
	1	1	data_flag	-	-	-	-	-	-	-

To stop data transmission, this command must be issued to check the data_flag.

Data_flag: Data flag of receiving user data.

0: Driver didn't receive all the data.

1: Driver has already received all the one-frame data.

This command can be active only when BUSY_N = "1". After data start (10h) and data stop (11h) command, BUSY_N signal will become "0".

(10) DISPLAY REFRESH (DRF) (R12H)

Action	W/R	C/D	D7	D6	D5	D4	D3	D2	D1	D0
Refreshing the display	0	0	0	0	0	1	0	0	1	0

While user sent this command, driver will refresh display (data/VCOM) according to SRAM data and LUT.

This command can be active only when BUSY_N = "1". After display refresh command, BUSY_N signal will become "0".

(11) DATA START TRANSMISSION 2 (DTM2) (R13H)

Action	W/R	C/D	D7	D6	D5	D4	D3	D2	D1	D0
Starting data transmission	0	0	0	0	0	1	0	0	1	1
	0	1	RPixel1	RPixel2	RPixel3	RPixel4	RPixel5	RPixel6	RPixel7	RPixel8
	0	1	:	:	:	:	:	:	:	:
	0	1	RPixel(n-1)	RPixel(n)	-	-	-	-	-	-

This command starts transmitting data and write them into SRAM. To complete data transmission, command DSP (Data transmission Stop) must be issued. Then the chip will start to send data/VCOM for panel.

This command can be active only when BUSY_N = "1".

RPixel(x):

DDX	RPixel (x)	LUT
0	0	Red1
	1	Red0
1	0	Red0
	1	Red1

(12) Vcom1 LUT (LUTC1) (R20H)

Action	W/R	C/D	D7	D6	D5	D4	D3	D2	D1	D0
Build Look-up Table for Vcom 1 (16-byte command, Bytes 2~4 repeated 5 times)	0	0	0	0	1	0	0	0	0	0
	0	1	LEVEL SELECT.		NUMBER OF FRAMES					
	0	1	LEVEL SELECT.		NUMBER OF FRAMES.					
	0	1	TIMES TO REPEAT							
	0	1	:	:	:	:	:	:	:	:
	0	1	:	:	:	:	:	:	:	:
	0	1	:	:	:	:	:	:	:	:
	0	1	:	:	:	:	:	:	:	:
	0	1	:	:	:	:	:	:	:	:
	0	1	:	:	:	:	:	:	:	:

This command stores VCOM Look-Up Table with 5 groups of data. Each group contains information for one phase and is stored with 3 bytes, while the third byte indicates how many times that phase will repeat.

Bytes 2, 3, 5, 6, 8, 9, 11, 12, 14, 15:

{D7:D6}: Level selection. 00b: VCM_DC 01b: 15V+VCM_DC (VCOMH) 10b: -15V+VCM_DC (VCOML) 11b: Floating

{D5:D0}: Number of Frames. 00 0000b~11 1111b: 0 ~ 63 frames, respectively.

Bytes 4, 7, 10, 13, 16:

{D7:D0}: Times to repeat

(13) WHITE LUT (LUTW) (R21H)

This command builds Look-up Table for White. Please refer to command (12) Vcom1 LUT (LUTC1) for similar definition details.

(14) BLACK LUT (LUTB) (R22H)

This command builds Look-up Table for Black. Please refer to command (12) Vcom1 LUT (LUTC1) for similar definition details.

(15) GRAY1 LUT (LUTG1) (R23H)

This command builds Look-up Table for Gray 1. Please refer to command (12) Vcom1 LUT (LUTC1) for similar definition details.

(16) GRAY2 LUT (LUTG2) (R24H)

This command builds Look-up Table for Gray 2. Please refer to command (12) Vcom1 LUT (LUTC1) for similar definition details.

For commands (13)~(16), Level selection: 00b: 0V 01b: 15V (VSH) 10b: -15V (VSL) 11b: floating

(17) Vcom2 LUT (LUTC2) (R25H)

This command builds Look-up Table for Vcom 2. Please refer to command (12) Vcom1 LUT (LUTC1) for similar definition details.

Level selection: 00b: VCM_DC 01b: VSH (red)+VCM_DC(VCOMH) 10b: VSL (red)+VCM_DC(VCOML) 11b: floating

(18) RED0 LUT (LUTR0) (R26H)

This command builds Look-up Table for Red 0. Please refer to command (12) Vcom1 LUT (LUTC1) for similar definition details.

(19) RED1 LUT (LUTR1) (R27H)

This command builds Look-up Table for Red 1. Please refer to command (12) Vcom1 LUT (LUTC1) for similar definition details.

For commands (18)~(19), Level selection: 00b: 0V 01b: VSH (red) 10b: VSL (red) 11b: floating

(20) PLL CONTROL (PLL) (R30H)

Action	W/R	C/D	D7	D6	D5	D4	D3	D2	D1	D0
Controlling PLL	0	0	0	0	1	1	0	0	0	0
	0	1	-	-	M[2:0]			N[2:0]		

The command controls the PLL clock frequency. The PLL structure must support the following frame rates:

M	N	Frame rate	M	N	Frame rate	M	N	Frame rate	M	N	Frame rate
1	1	20 Hz	3	1	59 Hz	5	1	98 Hz	7	1	137 Hz
	2	10 Hz		2	29 Hz		2	50 Hz (default)		2	68 Hz
	3	7 Hz		3	20 Hz		3	33Hz		3	46 Hz
	4	5 Hz		4	15 Hz		4	24 Hz		4	34 Hz
	5	4 Hz		5	12 Hz		5	20 Hz		5	27 Hz
	6	3 Hz		6	10 Hz		6	16 Hz		6	23 Hz
	7	3 Hz		7	8 Hz		7	14 Hz		7	20 Hz
2	1	39 Hz	4	1	78 Hz	6	1	117 Hz			
	2	20 Hz		2	39 Hz		2	59 Hz			
	3	13 Hz		3	26 Hz		3	39 Hz			
	4	10 Hz		4	20 Hz		4	29 Hz			
	5	8 Hz		5	16 Hz		5	23 Hz			
	6	7 Hz		6	13 Hz		6	20 Hz			
	7	6 Hz		7	11 Hz		7	17 Hz			

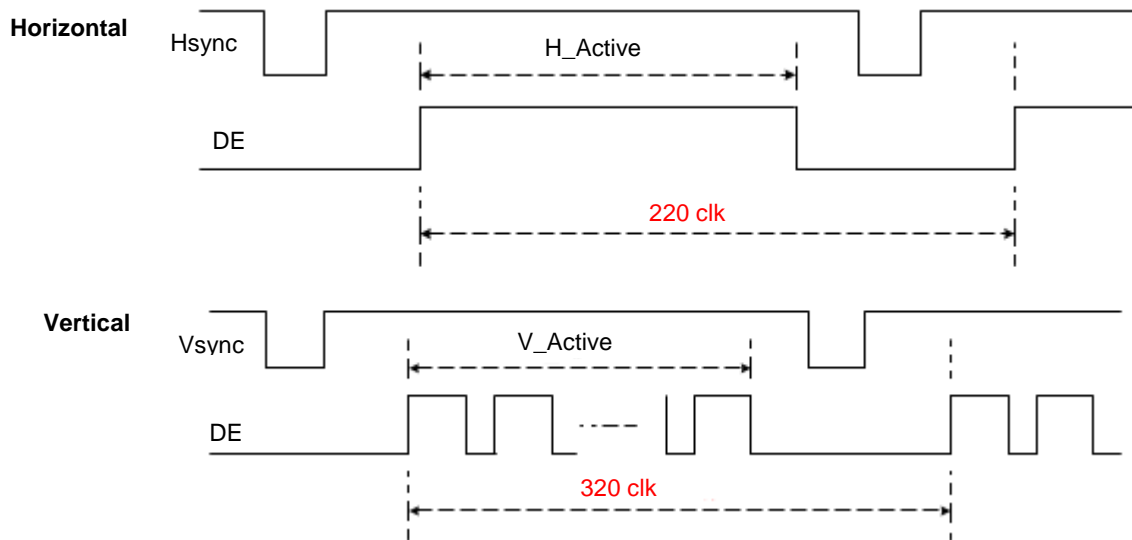

This command can be active only when BUSY_N = "1".

(21) TEMPERATURE SENSOR CALIBRATION (TSC) (R40H)

Action	W/R	C/D	D7	D6	D5	D4	D3	D2	D1	D0
Sensing Temperature	0	0	0	1	0	0	0	0	0	0
	1	1	D10	D9	D8	D7	D6 / TS3	D5 / TS2	D4 / TS1	D3 / TS0
	1	1	D2	D1	D0	-	-	-	-	-

This command reads the temperature sensed by the temperature sensor.

TS[3:0]: When TSE (R41h) is set to 0, this command reads internal temperature sensor value.

D[10:0]: When TSE (R41h) is set to 1, this command reads external LM75 temperature sensor value.

(22) TEMPERATURE SENSOR ENABLE (TSE) (R41H)

Action	W/R	C/D	D7	D6	D5	D4	D3	D2	D1	D0
Calibrate Temperature Sensor	0	0	0	1	0	0	0	0	0	1
	0	1	TSE	-	-	-	-	-	-	-

This command selects Internal or External temperature sensor.

TSE: Internal temperature sensor switch

0: Enable (default)

1: Disable; using external sensor.

(23) TEMPERATURE SENSOR WRITE (TSW) (R42H)

Action	W/R	C/D	D7	D6	D5	D4	D3	D2	D1	D0
Calibrate Temperature Sensor	0	0	0	1	0	0	0	0	1	0
	0	1	WATTR[7:0]							
	0	1	WMSB[7:0]							
	0	1	WLSB[7:0]							

This command reads the temperature sensed by the temperature sensor.

WATTR: **D[7:6]:** I²C Write Byte Number

00 : 1 byte (head byte only)

01 : 2 bytes (head byte + pointer)

10 : 3 bytes (head byte + pointer + 1st parameter)

11 : 4 bytes (head byte + pointer + 1st parameter + 2nd parameter)

D[5:3]: User-defined address bits (A2, A1, A0)

D[2:0]: Pointer setting

WMSB[7:0]: MSByte of write-data to external temperature sensor

WLSB[7:0]: LSByte of write-data to external temperature sensor

(24) TEMPERATURE SENSOR READ (TSR) (R43H)

Action	W/R	C/D	D7	D6	D5	D4	D3	D2	D1	D0
Calibrate Temperature Sensor	0	0	0	1	0	0	0	0	1	1
	1	1	RMSB[7:0]							
	1	1	RLSB[7:0]							

This command reads the temperature sensed by the temperature sensor.

RMSB[7:0]: MSByte read data from external temperature sensor

RLSB[7:0]: LSByte read data from external temperature sensor

(25) VCOM AND DATA INTERVAL SETTING (CDI) (R50H)

Action	W/R	C/D	D7	D6	D5	D4	D3	D2	D1	D0
Set Interval between Vcom and Data	0	0	0	1	0	1	0	0	0	0
	0	1	-	-	SD_BDHZ	DDX	CDI[3:0]			

This command indicates the interval of Vcom and data output. When setting the vertical back porch, the total blanking will be kept (20 Hsync). This command can be active only when BUSY_N = "1".

SD_BDHZ: Border output selection
 0 : Border output normal voltage
 1 : Border floating

DDX: Internal temperature sensor switch

0: 0 – white / 1 – black

1: 0 – black / 1 – white (default)

CDI[3:0]: Vcom and data interval

CDI[3:0]	Vcom and Data Interval
0000 b	17 hsync
0001	16
0010	15
0011	14
0100	13
0101	12
0110	11
0111	10 (Default)

CDI[3:0]	Vcom and Data Interval
1000	9
1001	8
1010	7
1011	6
1100	5
1101	4
1110	3
1111	2

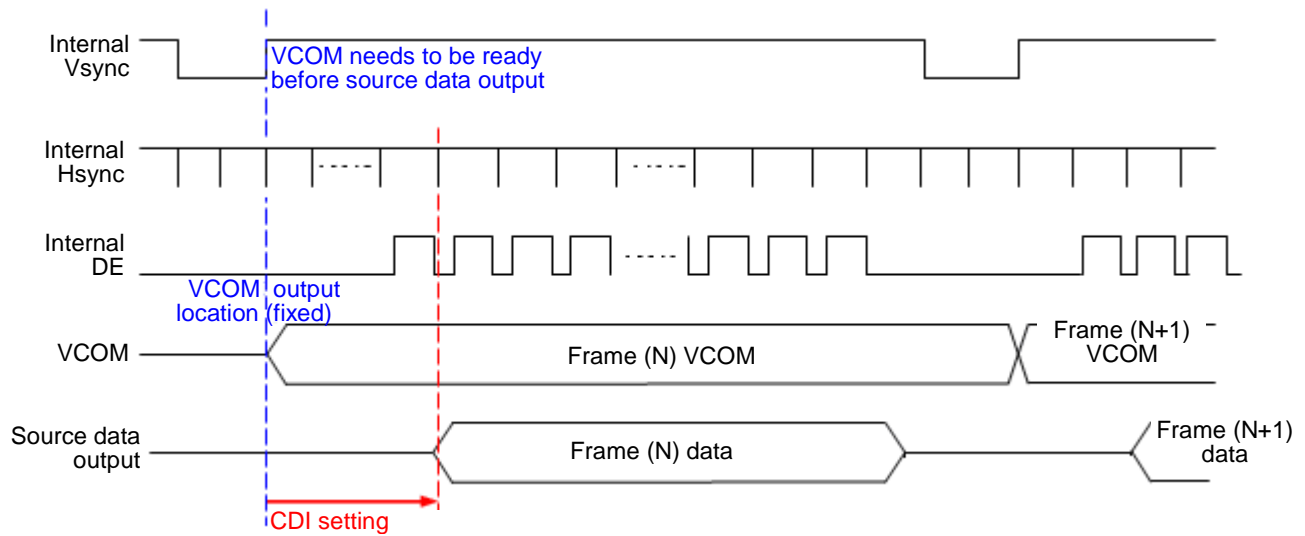

(26) LOW POWER DETECTION (LPD) (R51H)

Action	W/R	C/D	D7	D6	D5	D4	D3	D2	D1	D0
Detect Low Power	0	0	0	1	0	1	0	0	0	1
	1	1	-	-	-	-	-	-	-	LPD

This command indicates the input power condition. Host can read this flag to learn the battery condition.

LPD: Internal temperature sensor switch

0: Low power input (VDD<2.5V)

1: Normal status (default)

(27) TCON SETTING (TCON) (R60H)

Action	W/R	C/D	D7	D6	D5	D4	D3	D2	D1	D0
Sensing Temperature	0	0	0	1	1	0	0	0	0	0
	0	1	S2G[3:0]				G2S[3:0]			

This command defines non-overlap period of Gate and Source. This command can be active only when BUSY_N = "1".

S2G[3:0] or G2S[3:0]: Source to Gate / Gate to Source Non-overlap period

S2G[3:0] or G2S[3:0]	Period	S2G[3:0] or G2S[3:0]	Period
0000 b	4 clock	1000 b	36
0001	8	1001	40
0010	12 (Default)	1010	44
0011	16	1011	48
0100	20	1100	52
0101	24	1101	56
0110	28	1110	(reserved)
0111	32	1111	(reserved)

Clock frequency is 2MHz.

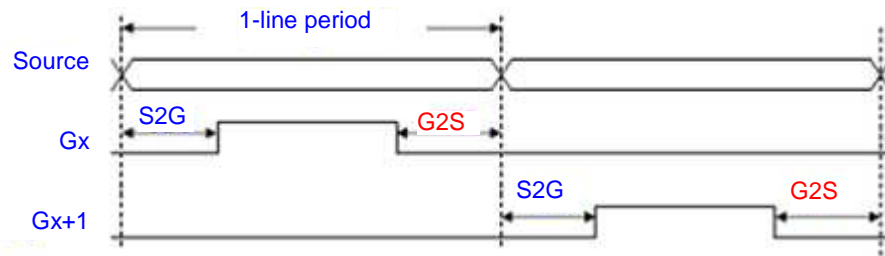

(28) RESOLUTION SETTING (TRES) (R61H)

Action	W/R	C/D	D7	D6	D5	D4	D3	D2	D1	D0	
Set Display Resolution	0	0	0	1	1	0	0	0	0	1	
	0	1	HRES[7:1]							0	
	0	1	-	-	-	-	-	-	-	-	VRES[8]
	0	1	VRES[7:0]								

This command defines alternative resolution and this setting is of higher priority than the RES[1:0] in R00H (PSR).

HRES[7:1]: Horizontal Display Resolution

VRES[8:0]: Vertical Display Resolution

Active channel calculation:

GD : First G active = G0; LAST active GD= first active +VRES -1

SD : First active channel: =S0 ; LAST active SD= first active +HRES-1

EX :128x296

GD: First G active = G0, LAST active GD= 0+296-1= 295; (G295)

SD: First active channel = S0, LAST active SD= 0+128-1=93; (S127)

This command can be active only when BUSY_N = "1".

(29) REVISION (REV) (R70H)

Action	W/R	C/D	D7	D6	D5	D4	D3	D2	D1	D0
Chip Revision	0	0	0	1	1	1	0	0	0	0
	1	1	0	0	0	0	0			

This command can be active only when BUSY_N = "1".

(30) GET STATUS (FLG) (R71H)

Action	W/R	C/D	D7	D6	D5	D4	D3	D2	D1	D0
Read Flags	0	0	0	1	1	1	0	0	0	1
	1	1	-	-	I ² C_ERR	I ² C_BUSYN	data_flag	PON	POF	BUSY_N

This command reads the IC status.

I²C_ERR: I²C master error status

I²C_BUSYN: I²C master busy status (low active)

data_flag: Driver has already received all the one frame data

PON: Power ON status

POF: Power OFF status

BUSY_N: Driver busy status (low active)

(31) AUTO MEASURE VCOM (AMV) (R80H)

Action	W/R	C/D	D7	D6	D5	D4	D3	D2	D1	D0
Automatically measure Vcom	0	0	1	0	0	0	0	0	0	0
	0	1	-	-	AMVT[1:0]	-	-	AMV	AMVE	

This command reads the IC status.

AMVT[1:0]: Auto Measure Vcom Time

00b: 3s

01b: 5s (default)

10b: 8s

11b: 10s

AMV: 0 – Get Vcom value with the VV command (R81h)

1 – Get Vcom value in analog signal.

AMVE: Auto Measure Vcom Enable (/Disable)

0 – No effect

1 – Trigger auto Vcom sensing.

This command can be active only when BUSY_N = "1".

(32) VCOM VALUE (VV) (R81H)

Action	W/R	C/D	D7	D6	D5	D4	D3	D2	D1	D0
Automatically measure Vcom	0	0	1	0	0	0	0	0	0	1
	1	1	-	-	VV[5:0]					

This command gets the Vcom value.

VV[5:0]: Vcom Value

VV[5:0]	Vcom value
00 0000b	0 V
00 0001b	-0.1 V
00 0010b	-0.2 V
:	:
01 0100b	-2.0 V (Default)
:	:
10 1000b	-4.0 V
10 1001b	-4.1 V
:	:
11 1111b	-6.3 V

This command can be active only when BUSY_N = "1".

(33) VCM_DC SETTING (VDCS) (R82H)

Action	W/R	C/D	D7	D6	D5	D4	D3	D2	D1	D0
Set VCM_DC	0	0	1	0	0	0	0	0	1	0
	0	1	-	-	VDCS[5:0]					

This command sets VCOM_DC value

VDCS[5:0]: Vcom Value

VDCS[5:0]	Vcom value
00 0000b	0 V (Default)
00 0001b	-0.1 V
00 0010b	-0.2 V
00 0011b	-0.3 V
:	:
01 1110b	-3.0 V
:	
11 1111b	

This command can be active only when BUSY_N = "1".

HOST INTERFACES

3-WIRE SPI

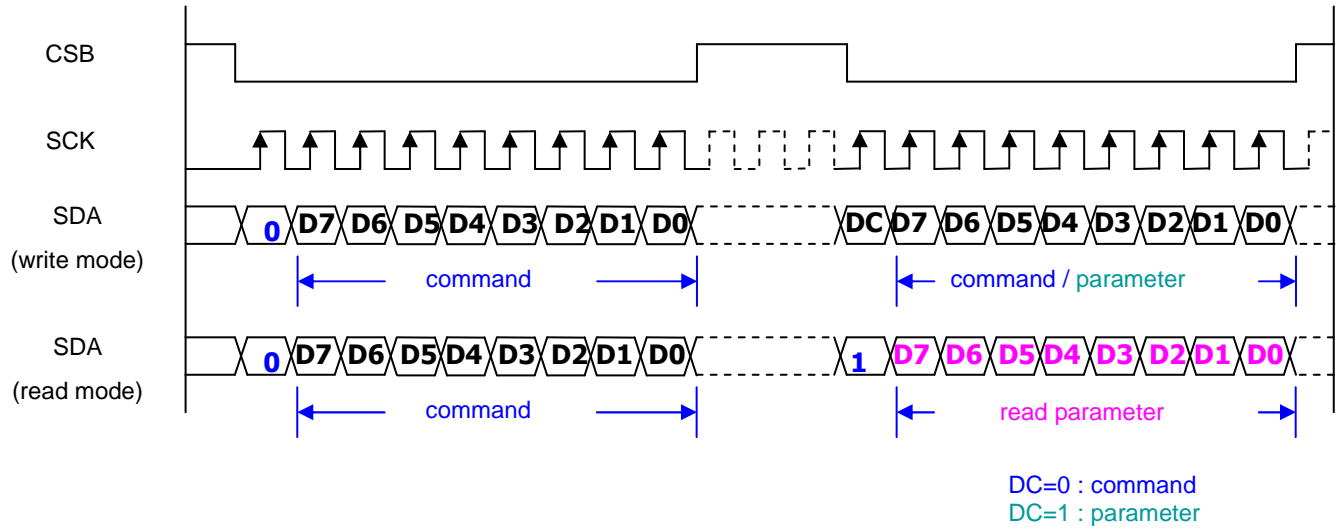

Figure : 3-wire SPI Typical Waveform – BS=1

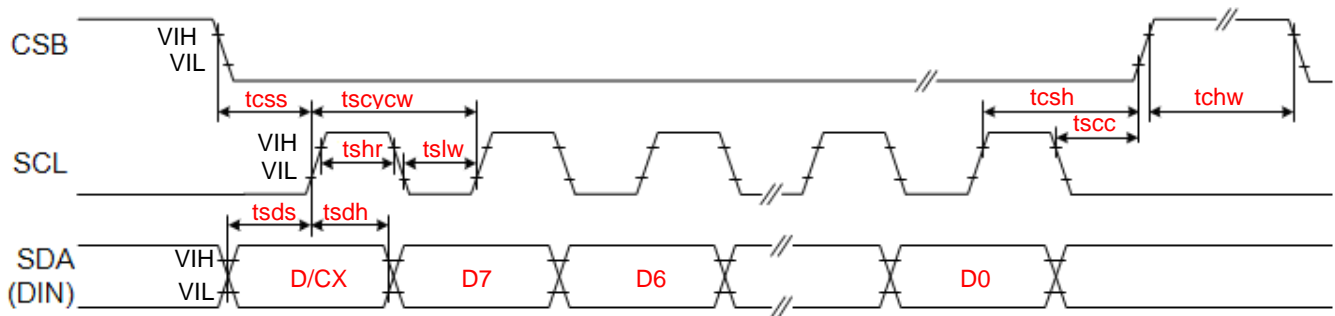

Figure : 3-wire Serial Interface – Write

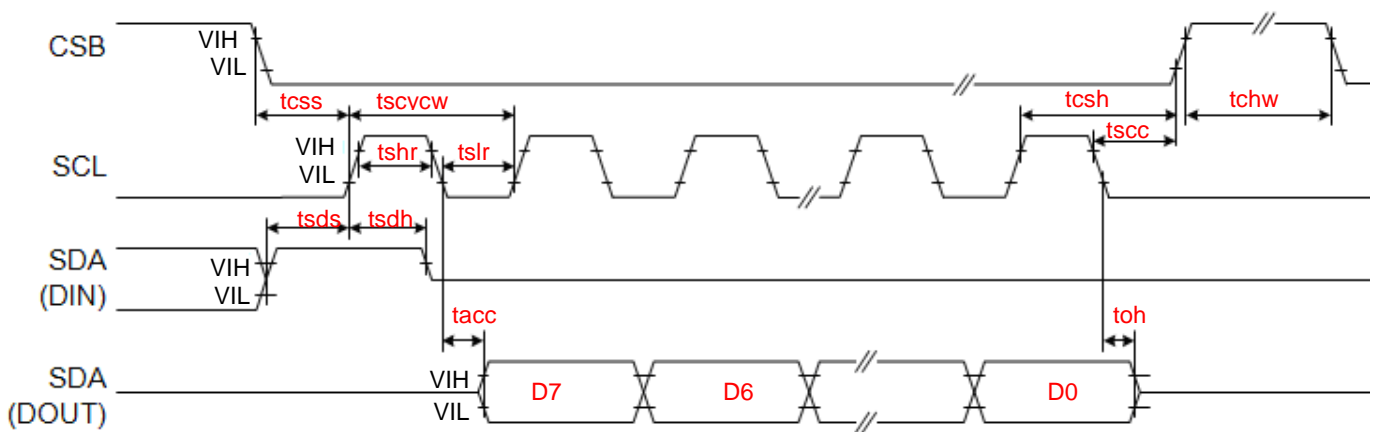
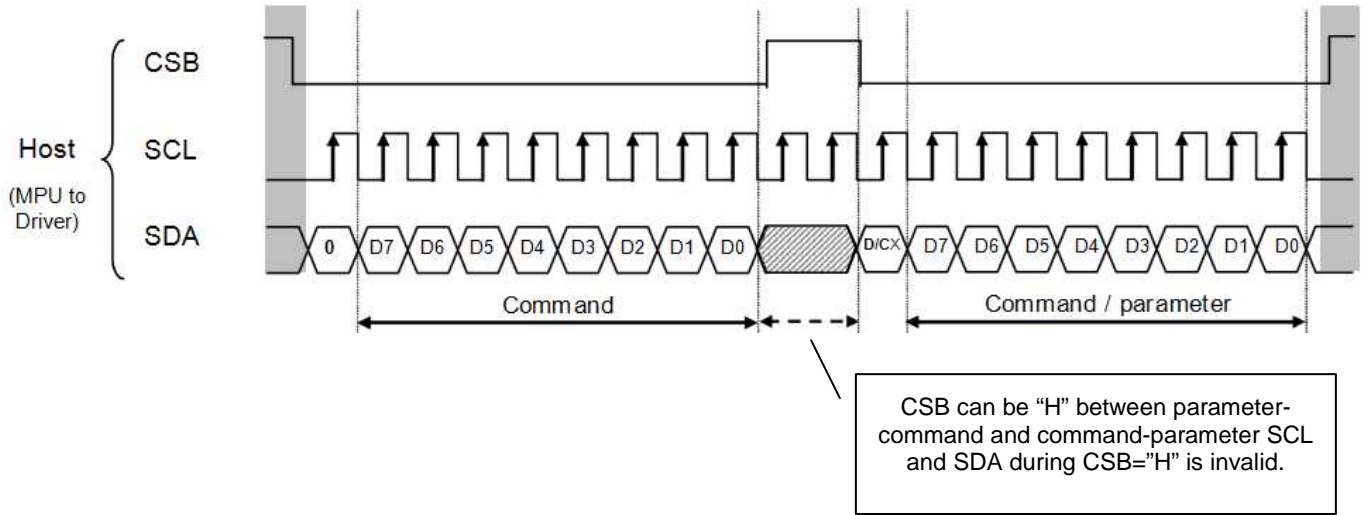

Figure : 3-wire Serial Interface – Read



4-WIRE SPI

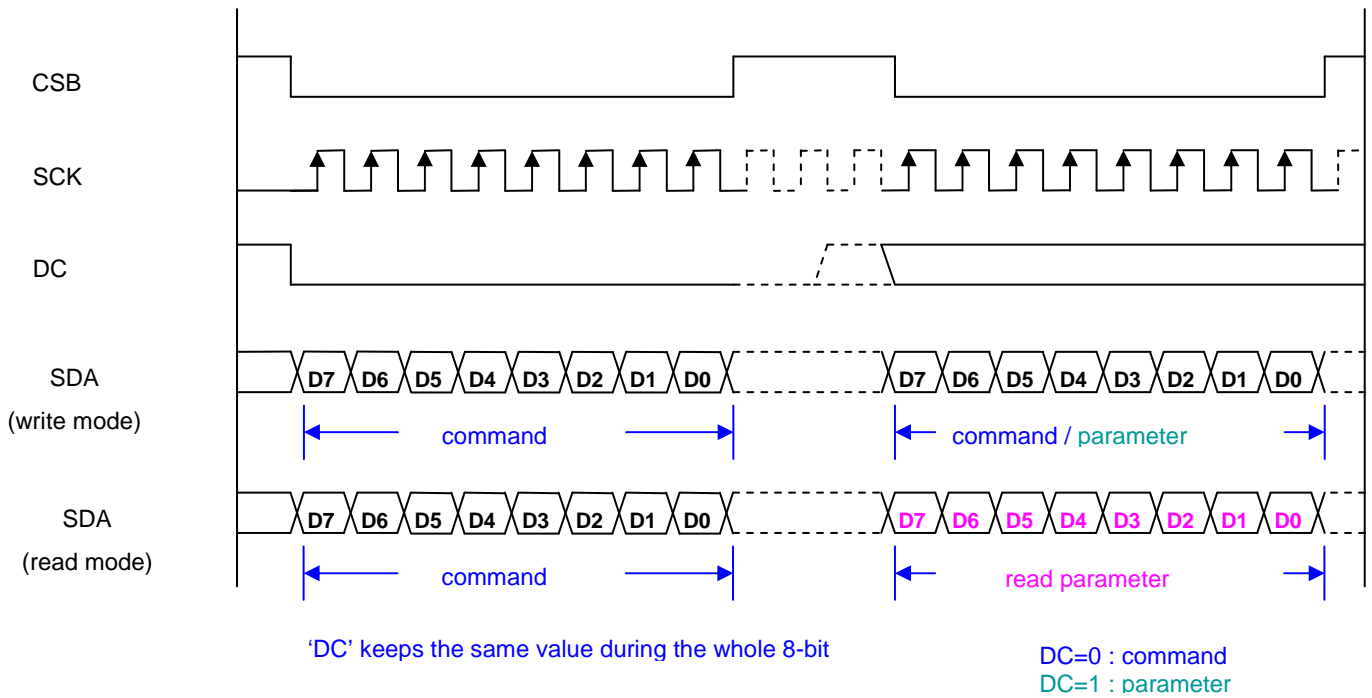

Figure : 4-wire SPI Typical Waveform – BS=0

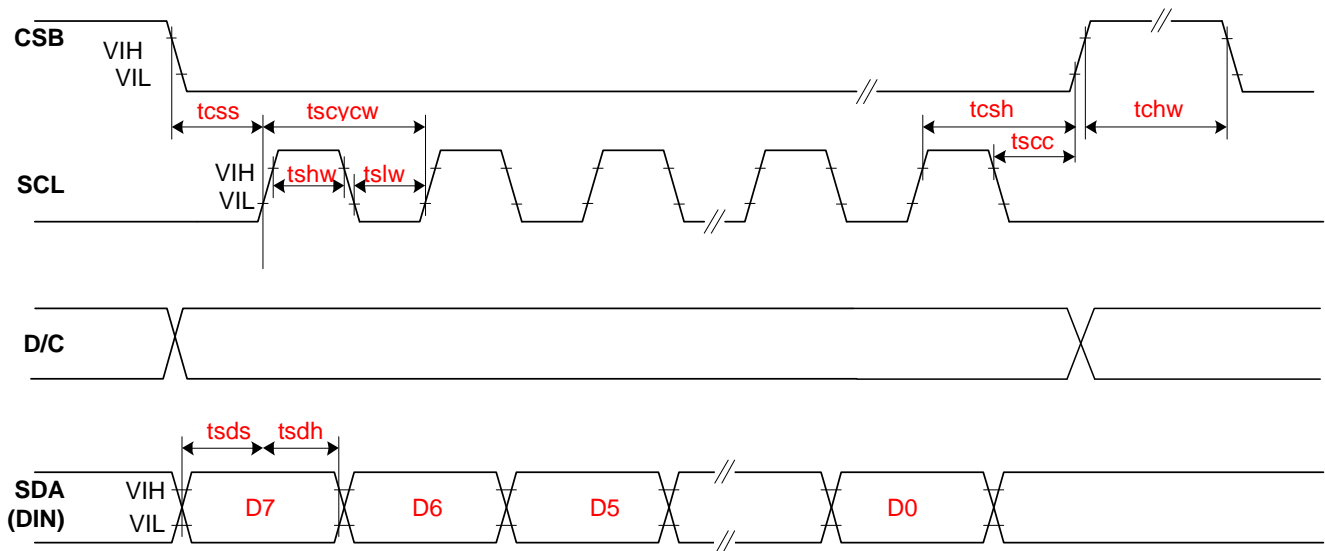
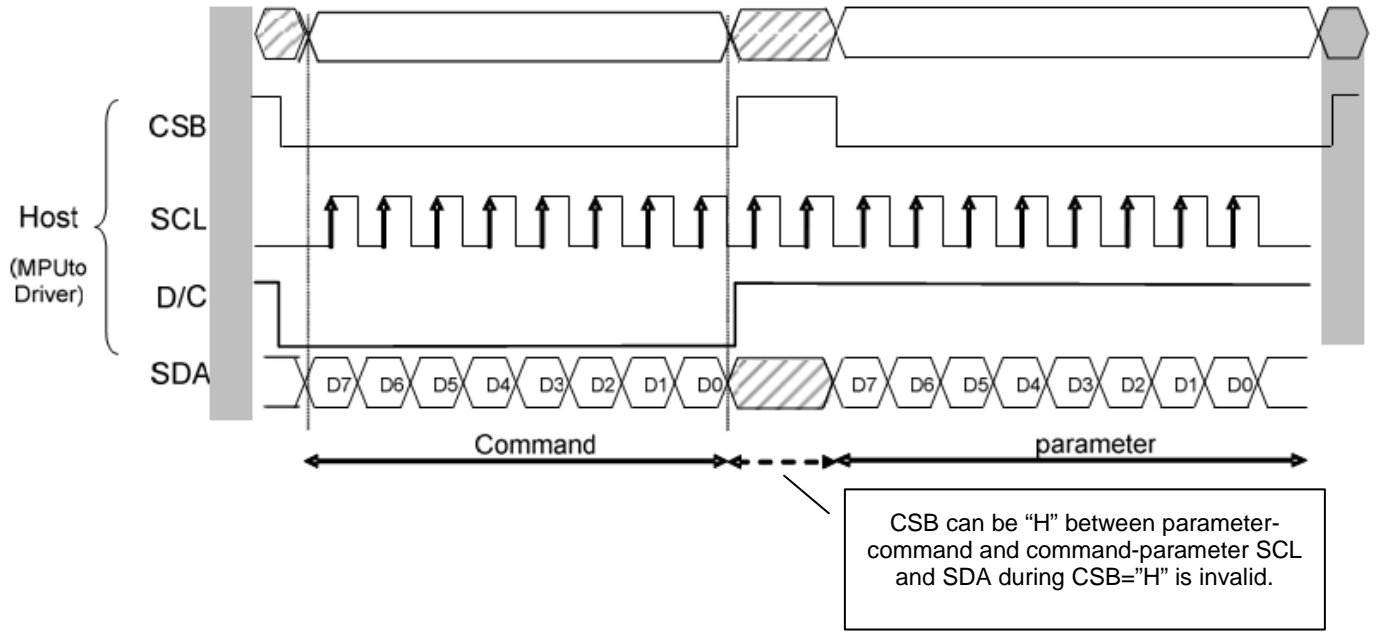
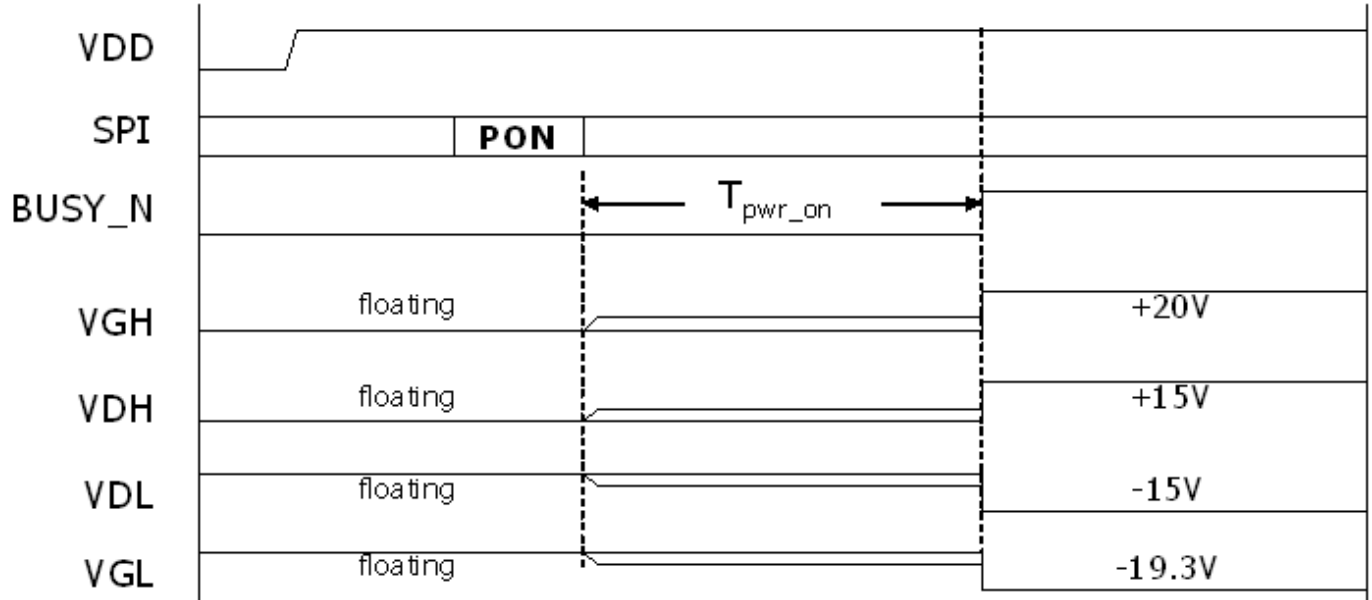

Figure : 4-wire Serial Interface – Read



POWER MANAGEMENT

Power ON Sequence



$T_{pwr_on} = \sim 80ms$ (default)

Power OFF Sequence

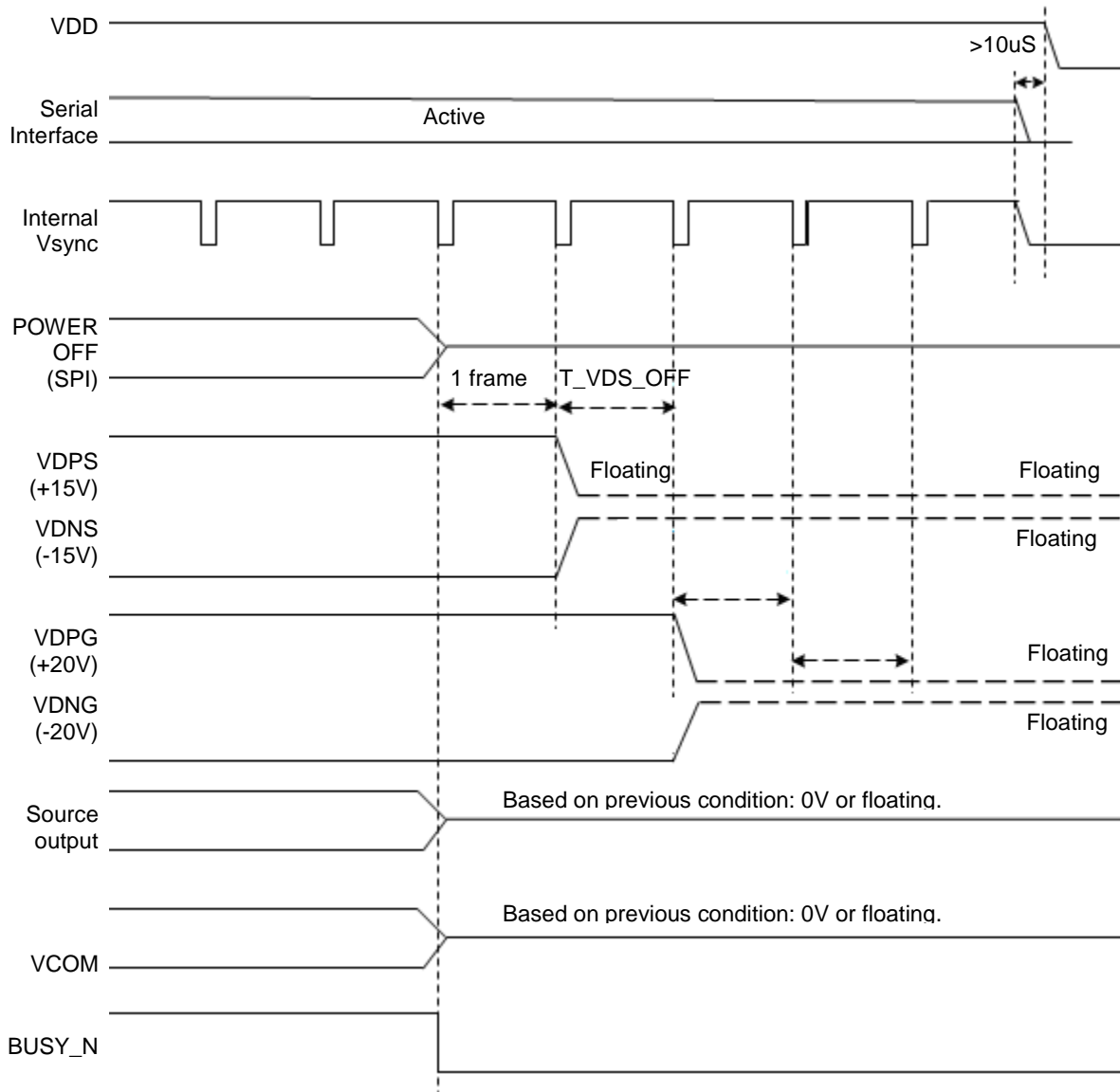

Data Transmission Waveform

Example 1: LUT all states (5 states) complete or phase number=0, the driver will send 2 frame VCOM and data to 0 V.

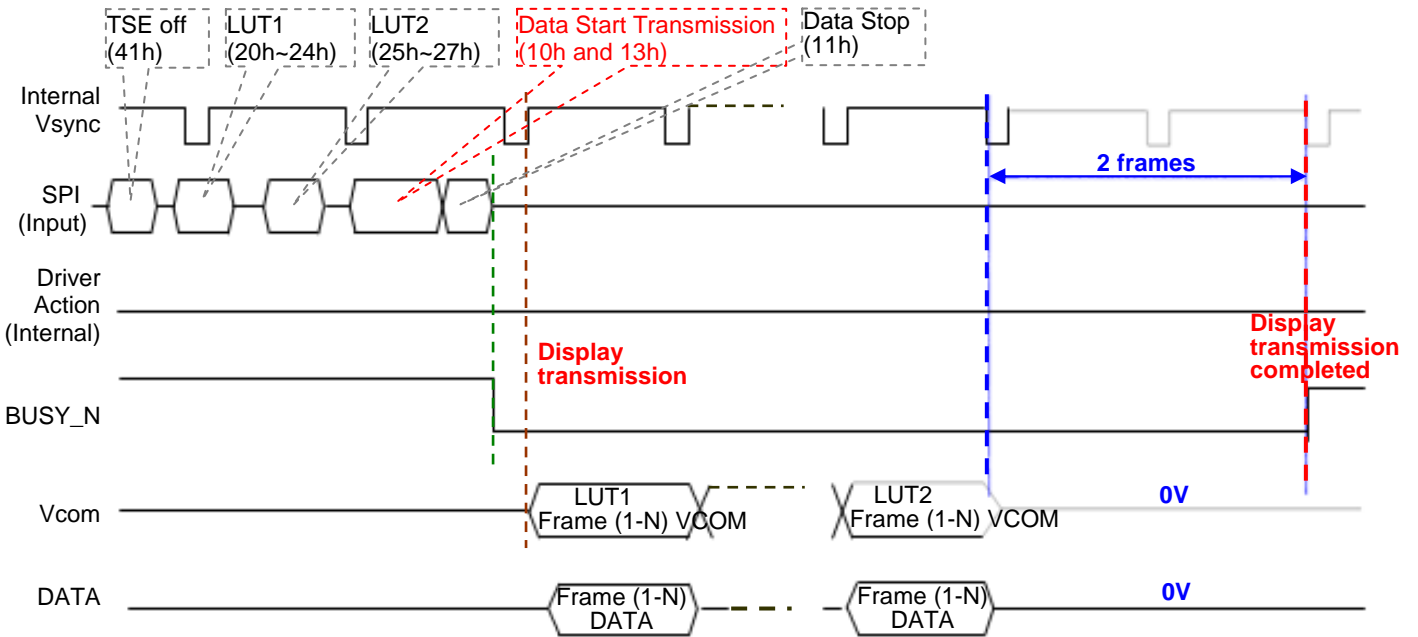

Example 2: While level selection in LUT is "11", the driver will float VCOM and data.

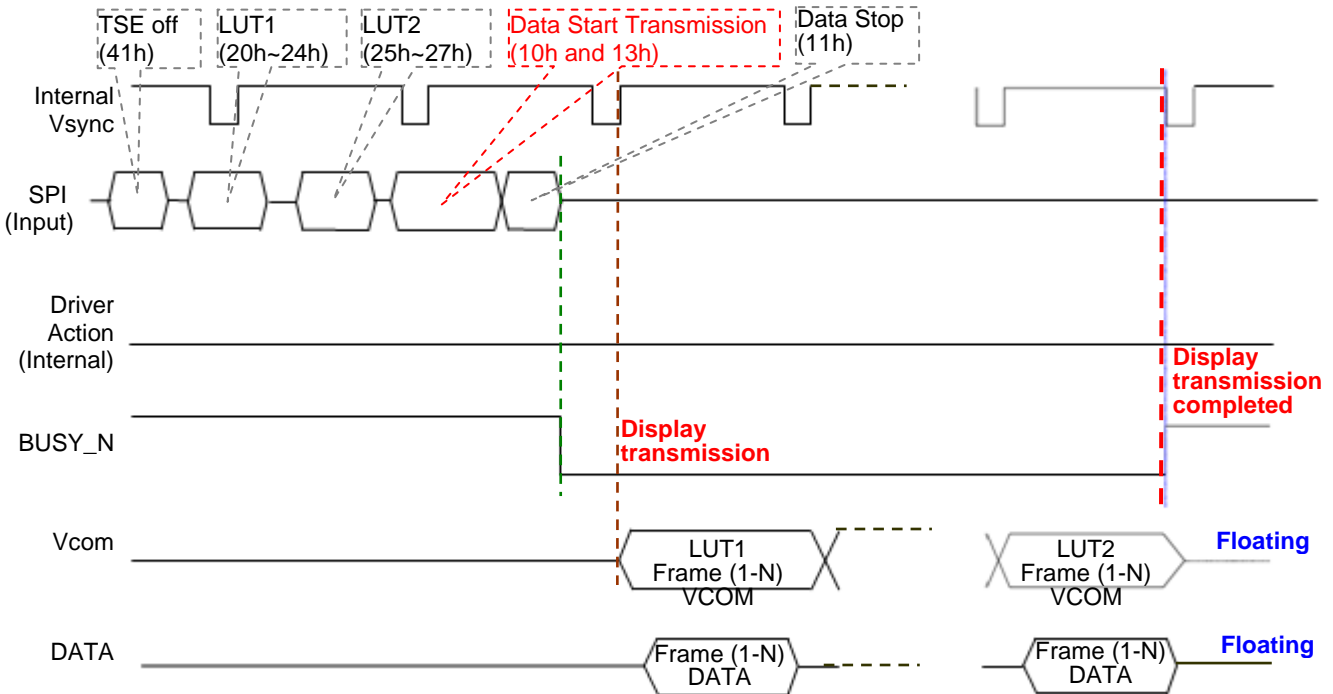

Display Refresh Waveform

Example 1: LUT all states (5 states) complete or phase number=0, the driver will send 2 frame VCOM and data to 0 V.

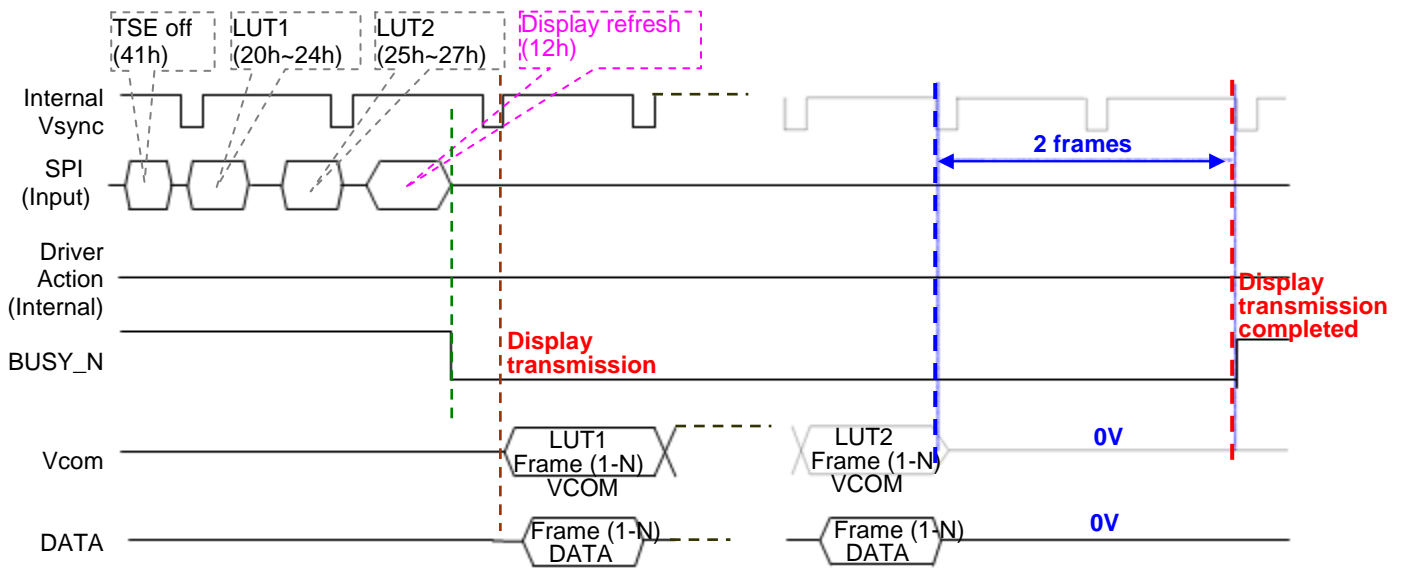

Example 2: While level selection in LUT is "11", the driver will float VCOM and data.

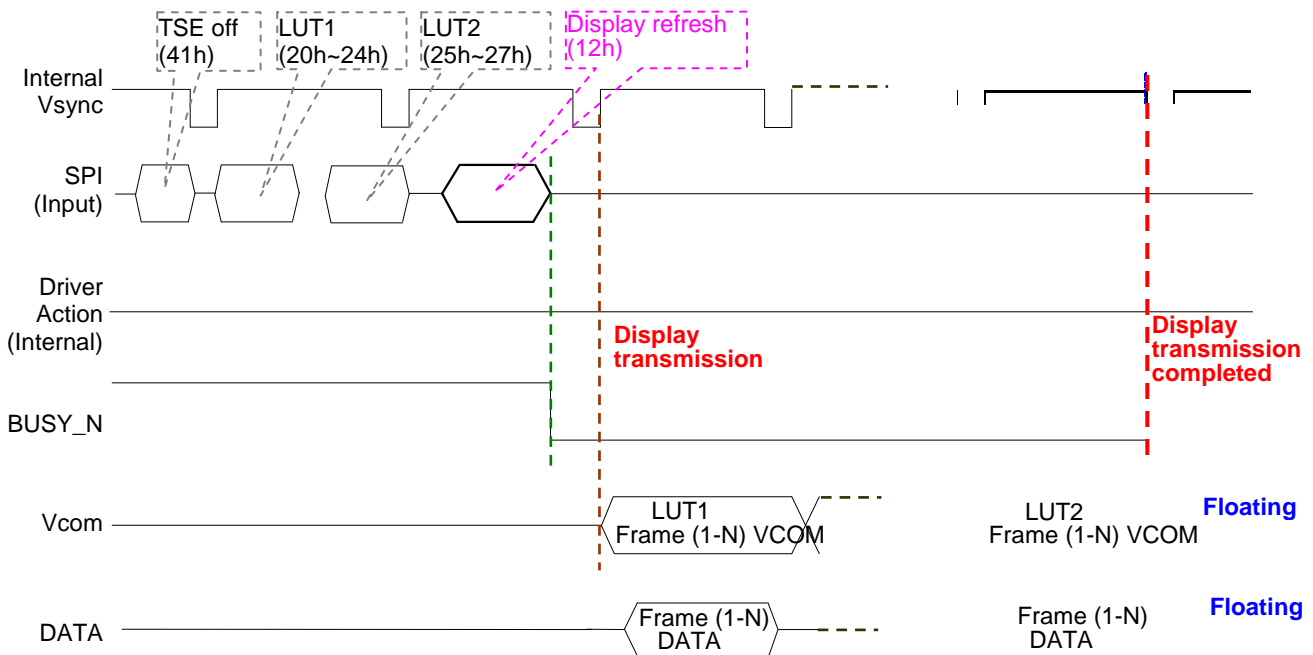

BUSY_N Signal Flow Chart

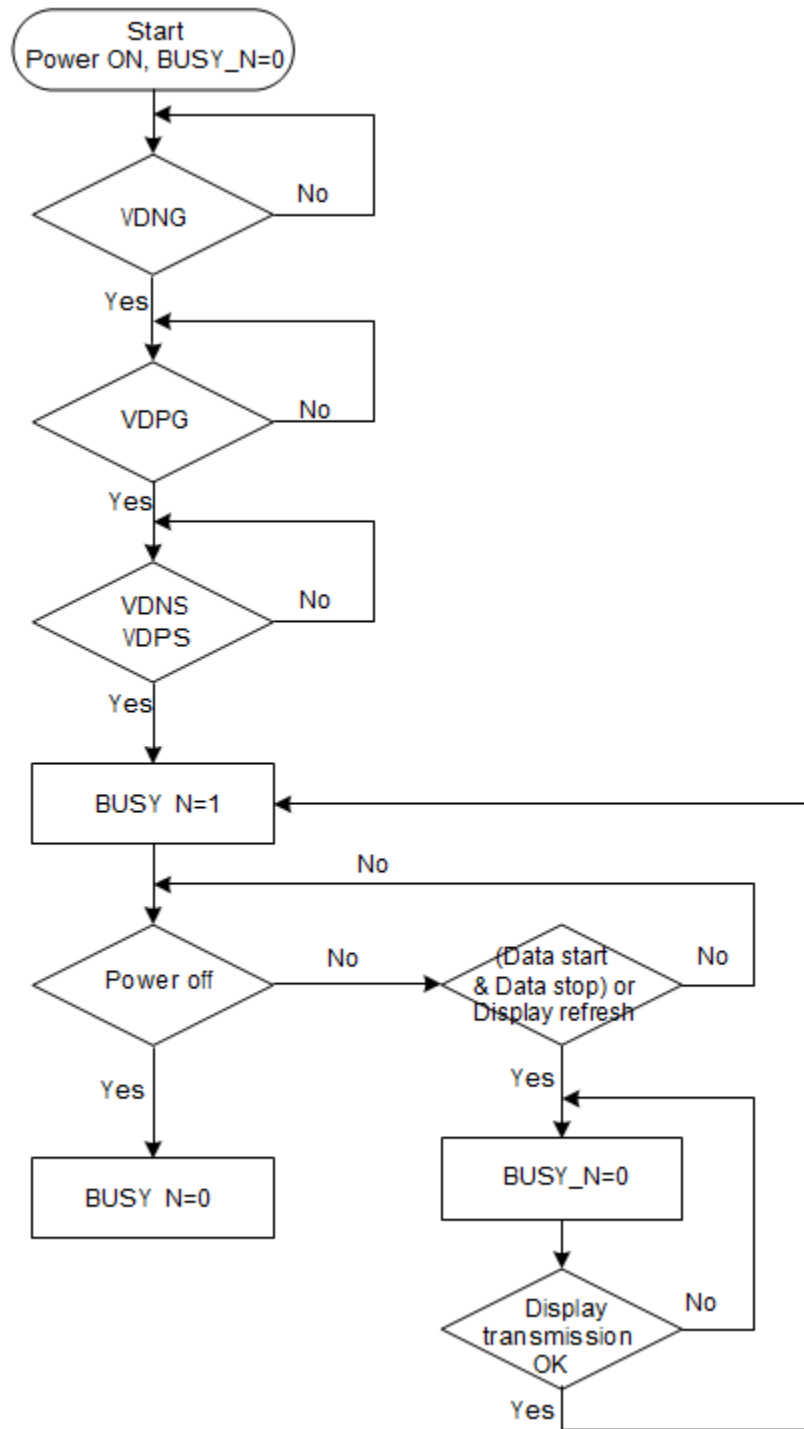

BUSY_N Signal Flow Chart

ABSOLUTE MAXIMUM RATINGS

VDD= 2~3.6V (Typ. 3.3V), GND=0V, VDH=3~9V (Typ. 6V), VDL=0~6V (Typ. 3V), TA=0~70°C (Typ. 25°C)

Signal	Item	Min	Max.	Unit
VDD, VIO, VDD1, VPP	Logic Supply voltage	- 0.3	+6.0	V
VI	Digital input range	-0.3	VDDIO+40	V
VDPS-VDNS	Supply range	VDNG-0.3	VDPG+0.3	V
Source				
VDPS	Analog supply voltage – positive		+20	V
VDNS	Analog supply voltage -- negative		-20	V
Gate				
VDPS	Analog supply voltage – positive	-0.3	VDNG+40	V
VDNS	Analog supply voltage -- negative	VDPG-40	0.3	V
IVDPS	Input rush current for VDPS	(TBD)	(TBD)	mA
IVDNS	Input rush current for VDNS	(TBD)	(TBD)	mA
TSTG	Storage temperature range	-55	+125	°C

Warning:

If ICs are stressed beyond those listed above “absolute maximum ratings”, they may be permanently destroyed. These are stress ratings only, and functional operation of the device at these or any other condition beyond those indicated under “recommended operating conditions” is not implied. Exposure to absolute maximum rated conditions for extended periods may affect device reliability.

DC CHARACTERISTICS

Symbol	Parameter	Conditions	MIN.	TYP.	MAX.	Unit
V _{IO}	IO supply voltage		2.3	3.3	3.6	V
V _{DD}	Supply voltage		2.3	3.3	3.6	V
V _{DD1}	DCDC driver supply voltage	DRVU, DRVD	2.3	3.3	3.6	V
V _{IL}	LOW Level input voltage	Digital input pins	0	--	0.3xV _{DD}	V
V _{IH}	HIGH Level input voltage	Digital input pins	0.7xV _{IO}	--	V _{IO}	V
V _{OH}	HIGH Level output voltage	Digital input pins, I _{OH} =400uA	V _{IO} -0.4	--	--	V
V _{OHD}	HIGH Level output voltage	Digital input pins, I _{OH} =400uA, DRVD, DRVU	V _{DD1} -0.4	--	--	V
V _{OL}	LOW Level Output voltage	Digital input pins, I _{OL} =-400uA	0	--	0.4	V
I _{IN}	Input leakage current	Digital input pins except pull-up, pull-down pin	-1	--	1	uA
I _{SLP}	Sleep Current	V _{DD} =3.3 All stopped (Power OFF mode)			1	mA
R _{IN}	Pull-up/down impedance			200		KΩ
T _{OP}	Operating temperature		-30		85	°C
V _{DPS}	Supply Voltage	For source driver/VCOM		15		V
dV _{DPS}	Supply voltage dev		-300	0	+300	mV
V _{DNS}	Supply Voltage	For source driver/VCOM		-15		V
dV _{DNS}	Supply voltage dev		-300	0	+300	mV
I _{dd}	Analog Operating Current	No load,		TBD		mA
V _{VD}	Voltage Deviation of Outputs		--	±20	±35	mV
V _{DR}	Dynamic Range of Output		0.1	--	V _{DPS} -0.1	V
V _{DPG} - V _{DN} G	Voltage Range of V _{DPG} - V _{DN} G		12		40	V
V _{DN} G	V _{DN} G voltage Range	For gate driver	-20		-17	V
dV _{DN} G	V _{DN} G Supply voltage dev		-400	0	+400	mV
V _D PG	V _D PG voltage Range	For gate driver	17		V _{DN} G+40	V
dV _D PG	V _D PG Supply voltage dev		-400	0	+400	mV
I _{opr}	Operating Current	V _{DD} =3.3 DC/DC ON No waveform transitions No loading No RAM Read/Write		2		mA

AC CHARACTERISTICS

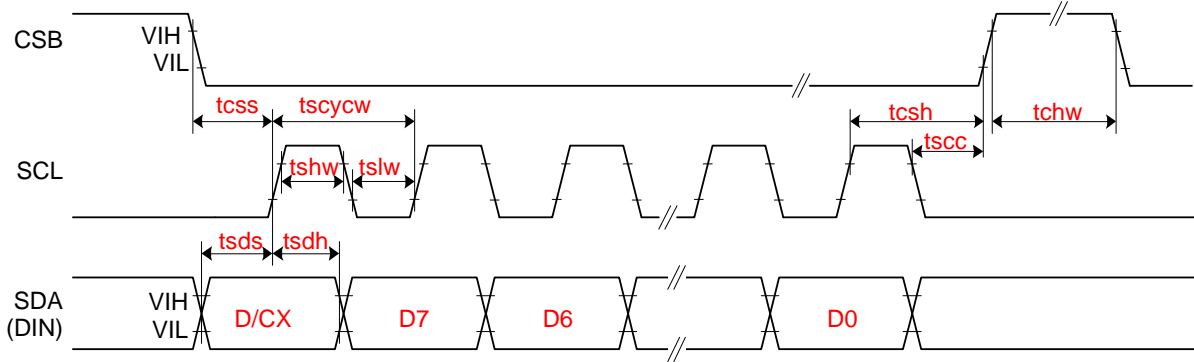

3-wire Serial Interface – Write

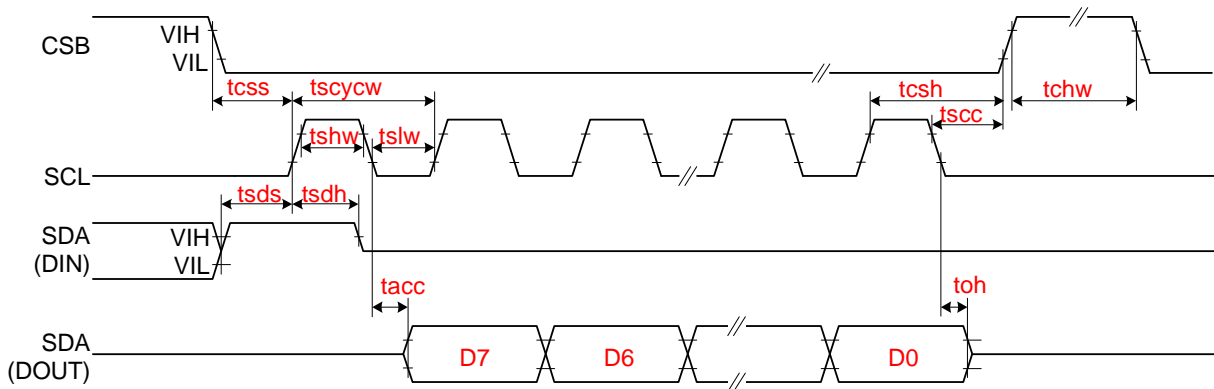

3-wire Serial Interface – Read

SYMBOL	SIGNAL		MIN.	TYP.	MAX.	UNIT
SERIAL COMMUNICATION						
tCSS	CSB	Chip select setup time	60			ns
tCSH		Chip select hold time	65			ns
tSCC		Chip select setup time	20			ns
tCHW		Chip select hold time	40			ns
tSCYCW	SCL	Serial clock cycle (Write)	100			ns
tSHW		SCL "H" pulse width (Write)	35			ns
tSLW		SCL "L" pulse width (Write)	35			ns
tSCYCR		Serial clock cycle (Read)	150			ns
tSHR		SCL "H" pulse width (Read)	60			ns
tSLR		SCL "L" pulse width (Read)	60			ns
tSDS	SDA (DIN) (DOUT)	Data setup time	30			ns
tSDH		Data hold time	30			ns
tACC		Access time	10			ns
tOH		Output disable time	15			ns

SYMBOL	SIGNAL			MIN.	TYP.	MAX.	UNIT
DRIVER							
trS		Source driver rise time	99% final value		5		us
tFS		Source driver fall time			5		us
trG		Gate driver rise time	99% final value		5		us
tFG		Gate driver fall time			5		us
trCOM		VCOM rise time	99% final value		1		ms
tFCOM		VCOM fall time			1		ms
RC LOADING							
RL_S		Source driver output loading			13.362		KΩ
CL_S					39.194		pf
RL_G		Gate driver output loading			12.329		KΩ
CL_G					32.095		pf
RL_com		VCOM output loading			61.26		Ω
CL_com					3365.7		pf

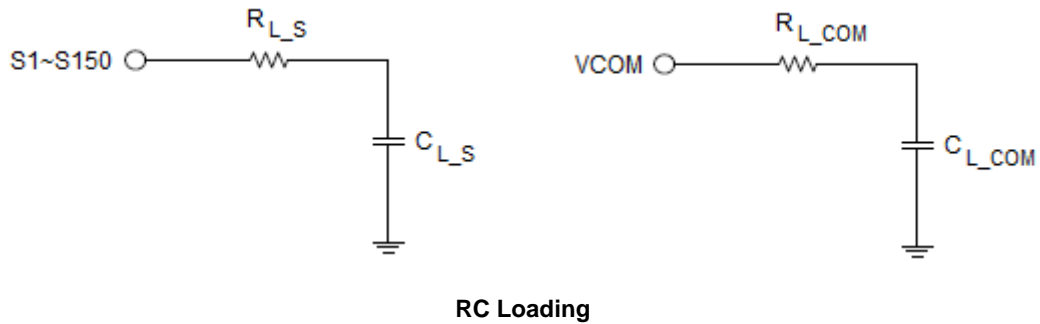

PHYSICAL DIMENSIONS

Die Size:	$(13090\mu\text{M} \pm 40\mu\text{M}) \times (1530\mu\text{M} \pm 40\mu\text{M})$
Die Thickness:	$300\mu\text{M} \pm 20\mu\text{M}$
Die TTV:	$(D_{\text{MAX}} - D_{\text{MIN}})$ within die $\leq 2\mu\text{M}$
Bump Height:	$12\mu\text{M} \pm 3\mu\text{M}$ $(H_{\text{MAX}} - H_{\text{MIN}})$ within die $\leq 2\mu\text{M}$
Hardness:	$65\text{Hv} \pm 15\text{Hv}$
Bump Size:	$18\mu\text{M} \times 75\mu\text{M} \pm 2\mu\text{M}$
Bump Pitch:	$42\mu\text{M}$
Bump Gap:	$24\mu\text{M} \pm 3\mu\text{M}$
Bump Area:	$1350\mu\text{M}^2$
Total Bump Area:	$114300\mu\text{M}^2$
Area Ratio:	1.761 : 1 (Output pad : Input pad) 1 : 1 (Side power pad)
Coordinate origin:	Chip center
Pad reference:	Pad center

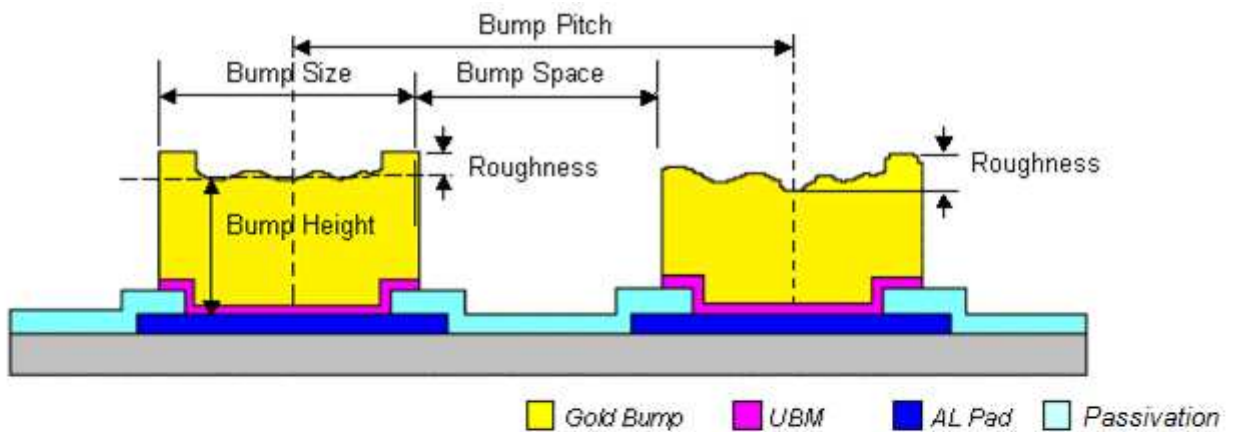

Bump Height Coplanarity within Die

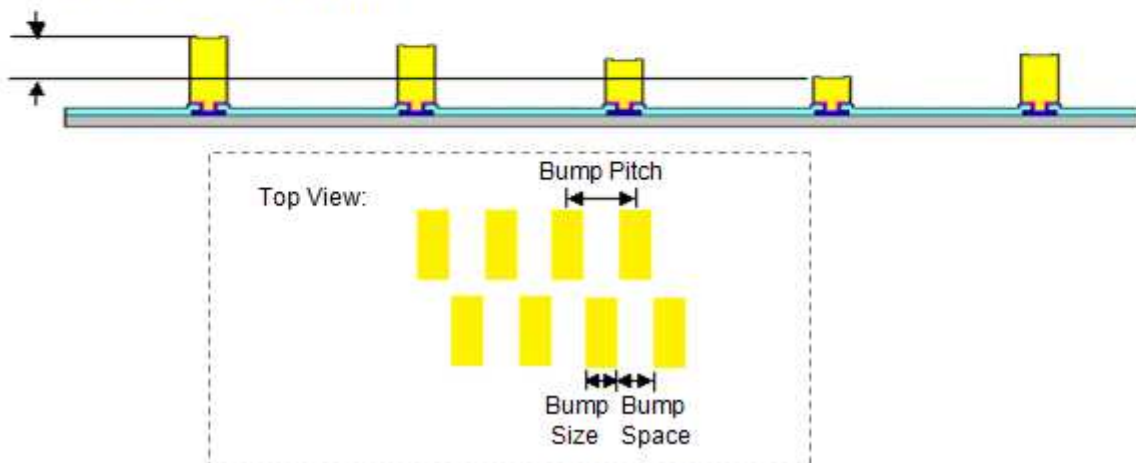

ALIGNMENT MARK INFORMATION

Location:

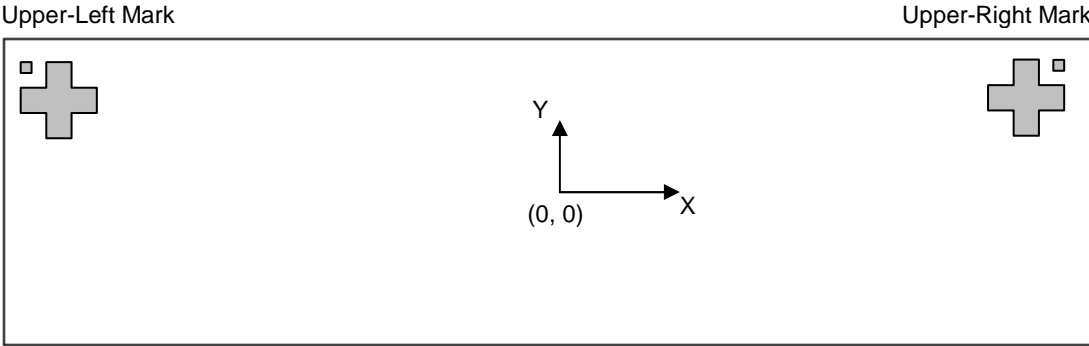

Shapes and Points:

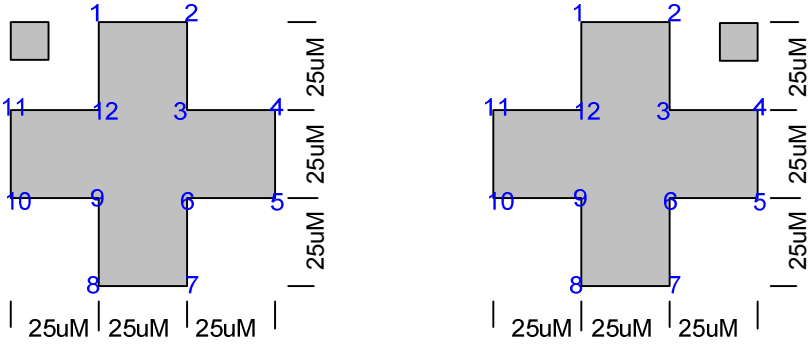

Point Coordinates:

Point	Upper-Left Mark		Upper-Right Mark	
	X	Y	X	Y
Center	-6382	642	6382	642
1	-6394.5	679.5	6369.5	679.5
2	-6369.5	679.5	6394.5	679.5
3	-6369.5	654.5	6394.5	654.5
4	-6344.5	654.5	6419.5	654.5
5	-6344.5	629.5	6419.5	629.5
6	-6369.5	629.5	6394.5	629.5
7	-6369.5	604.5	6394.5	604.5
8	-6394.5	604.5	6369.5	604.5
9	-6394.5	629.5	6369.5	629.5
10	-6419.5	629.5	6344.5	629.5
11	-6419.5	654.5	6344.5	654.5
12	-6394.5	654.5	6369.5	654.5

PAD COORDINATES

No.	Name	X	Y	W	H
1	NC	-6180	-680	40	50
2	VCOM	-6120	-680	40	50
3	VCOM	-6060	-680	40	50
4	VCOM	-6000	-680	40	50
5	VCOM	-5940	-680	40	50
6	VCOM	-5880	-680	40	50
7	VCOM	-5820	-680	40	50
8	VCOM	-5760	-680	40	50
9	VCOM	-5700	-680	40	50
10	VDM	-5640	-680	40	50
11	VGL	-5580	-680	40	50
12	VGL	-5520	-680	40	50
13	VGL	-5460	-680	40	50
14	VGL	-5400	-680	40	50
15	VGL	-5340	-680	40	50
16	VGL	-5280	-680	40	50
17	VGL	-5220	-680	40	50
18	VGL	-5160	-680	40	50
19	VGL	-5100	-680	40	50
20	VGL	-5040	-680	40	50
21	VGL	-4980	-680	40	50
22	VGL	-4920	-680	40	50
23	VGL	-4860	-680	40	50
24	VGL	-4800	-680	40	50
25	VGL	-4740	-680	40	50
26	VGL	-4680	-680	40	50
27	GND	-4620	-680	40	50
28	VSL	-4560	-680	40	50
29	VSL	-4500	-680	40	50
30	VSL	-4440	-680	40	50
31	VSL	-4380	-680	40	50
32	VSL	-4320	-680	40	50
33	VSL	-4260	-680	40	50
34	VSL	-4200	-680	40	50
35	VSL	-4140	-680	40	50
36	VSL	-4080	-680	40	50
37	VSL	-4020	-680	40	50
38	GND	-3960	-680	40	50
39	VGH	-3900	-680	40	50
40	VGH	-3840	-680	40	50
42	VGH	-3780	-680	40	50
41	VGH	-3720	-680	40	50
43	VGH	-3660	-680	40	50
44	VGH	-3600	-680	40	50
45	VGH	-3540	-680	40	50
46	VGH	-3480	-680	40	50
47	VGH	-3420	-680	40	50
48	VGH	-3360	-680	40	50
49	VGH	-3300	-680	40	50
50	VGH	-3240	-680	40	50
51	GND	-3180	-680	40	50
52	VSH	-3120	-680	40	50
53	VSH	-3060	-680	40	50
54	VSH	-3000	-680	40	50
55	VSH	-2940	-680	40	50
56	VSH	-2880	-680	40	50
57	VSH	-2820	-680	40	50
58	VSH	-2760	-680	40	50

No.	Name	X	Y	W	H
59	VSH	-2700	-680	40	50
60	VSH	-2640	-680	40	50
61	VSH	-2580	-680	40	50
62	GND	-2520	-680	40	50
63	DUMMY	-2460	-680	40	50
64	DUMMY	-2400	-680	40	50
65	DUMMY	-2340	-680	40	50
66	DUMMY	-2280	-680	40	50
67	DUMMY	-2220	-680	40	50
68	DUMMY	-2160	-680	40	50
69	DUMMY	-2100	-680	40	50
70	DUMMY	-2040	-680	40	50
71	DUMMY	-1980	-680	40	50
72	DUMMY	-1920	-680	40	50
73	DUMMY	-1860	-680	40	50
74	DUMMY	-1800	-680	40	50
75	DUMMY	-1740	-680	40	50
76	DUMMY	-1680	-680	40	50
77	DUMMY	-1620	-680	40	50
78	DUMMY	-1560	-680	40	50
79	GND	-1500	-680	40	50
80	VDM	-1440	-680	40	50
81	VDM	-1380	-680	40	50
82	GND	-1320	-680	40	50
83	GND	-1260	-680	40	50
84	GND	-1200	-680	40	50
85	GND	-1140	-680	40	50
86	GND	-1080	-680	40	50
87	GND	-1020	-680	40	50
88	GND	-960	-680	40	50
89	GND	-900	-680	40	50
90	GND	-840	-680	40	50
91	GND	-780	-680	40	50
92	GND	-720	-680	40	50
93	GND	-660	-680	40	50
94	GND	-600	-680	40	50
95	GND	-540	-680	40	50
96	GND	-480	-680	40	50
97	GND	-420	-680	40	50
98	GND	-360	-680	40	50
99	GND	-300	-680	40	50
100	GND	-240	-680	40	50
101	GND	-180	-680	40	50
102	GND	-120	-680	40	50
103	VDDA	-60	-680	40	50
104	VDDA	0	-680	40	50
105	VDDA	60	-680	40	50
106	VDDA	120	-680	40	50
107	VDDA	180	-680	40	50
108	VDDA	240	-680	40	50
109	VDDA	300	-680	40	50
110	VDDA	360	-680	40	50
111	VDDA	420	-680	40	50
112	VDDA	480	-680	40	50
113	VDD	540	-680	40	50
114	VDD	600	-680	40	50
115	VDD	660	-680	40	50
116	VDD	720	-680	40	50

No.	Name	X	Y	W	H
117	VDD	780	-680	40	50
118	VDD	840	-680	40	50
119	VDD	900	-680	40	50
120	TEST1	960	-680	40	50
121	TEST2	1020	-680	40	50
122	VDDIO	1080	-680	40	50
123	VDDIO	1140	-680	40	50
124	VDDIO	1200	-680	40	50
125	VDDIO	1260	-680	40	50
126	TEST3	1320	-680	40	50
127	DUMMY	1380	-680	40	50
128	DUMMY	1440	-680	40	50
129	DUMMY	1500	-680	40	50
130	DUMMY	1560	-680	40	50
131	DUMMY	1620	-680	40	50
132	SDA	1680	-680	40	50
133	SCL	1740	-680	40	50
134	GND	1800	-680	40	50
135	CSB	1860	-680	40	50
136	VDDIO	1920	-680	40	50
137	DUMMY	1980	-680	40	50
138	GND	2040	-680	40	50
139	DC	2100	-680	40	50
140	VDDIO	2160	-680	40	50
141	DUMMY	2220	-680	40	50
142	GND	2280	-680	40	50
143	RST_N	2340	-680	40	50
144	BUSY_N	2400	-680	40	50
145	CL	2460	-680	40	50
146	VDDIO	2520	-680	40	50
147	VSYN	2580	-680	40	50
148	GND	2640	-680	40	50
149	DUMMY	2700	-680	40	50
150	VDDIO	2760	-680	40	50
151	BS	2820	-680	40	50
152	GND	2880	-680	40	50
153	DUMMY	2940	-680	40	50
154	VDDIO	3000	-680	40	50
155	DUMMY	3060	-680	40	50
156	GND	3120	-680	40	50
157	MS	3180	-680	40	50
158	VDDIO	3240	-680	40	50
159	TSDA	3300	-680	40	50
160	TSDA	3360	-680	40	50
161	TSCL	3420	-680	40	50
162	TSCL	3480	-680	40	50
163	TEST4	3540	-680	40	50
164	TEST5	3600	-680	40	50
165	TEST6	3660	-680	40	50
166	TEST7	3720	-680	40	50
167	VGH	3780	-680	40	50
168	VGH	3840	-680	40	50
169	VGH	3900	-680	40	50
170	VGH	3960	-680	40	50
171	VGH	4020	-680	40	50
172	VGH	4080	-680	40	50
173	VGH	4140	-680	40	50
174	VGH	4200	-680	40	50
175	VGL	4260	-680	40	50
176	VGL	4320	-680	40	50

No.	Name	X	Y	W	H
177	VGL	4380	-680	40	50
178	VGL	4440	-680	40	50
179	VGL	4500	-680	40	50
180	VGL	4560	-680	40	50
181	VGL	4620	-680	40	50
182	VGL	4680	-680	40	50
183	GNDA	4740	-680	40	50
184	FB	4800	-680	40	50
185	FB	4860	-680	40	50
186	GNDA	4920	-680	40	50
187	RESE	4980	-680	40	50
188	RESE	5040	-680	40	50
189	GNDA	5100	-680	40	50
190	GDR	5160	-680	40	50
191	GDR	5220	-680	40	50
192	GDR	5280	-680	40	50
193	GDR	5340	-680	40	50
194	GDR	5400	-680	40	50
195	GDR	5460	-680	40	50
196	GDR	5520	-680	40	50
197	GDR	5580	-680	40	50
198	VDM	5640	-680	40	50
199	VCOM	5700	-680	40	50
200	VCOM	5760	-680	40	50
201	VCOM	5820	-680	40	50
202	VCOM	5880	-680	40	50
203	VCOM	5940	-680	40	50
204	VCOM	6000	-680	40	50
205	VCOM	6060	-680	40	50
206	VCOM	6120	-680	40	50
207	NC	6180	-680	40	50
208	NC	6170	561.5	18	75
209	NC	6149	681.5	18	75
210	NC	6128	561.5	18	75
211	NC	6107	681.5	18	75
212	NC	6086	561.5	18	75
213	NC	6065	681.5	18	75
214	G<0>	6044	561.5	18	75
215	G<2>	6023	681.5	18	75
216	G<4>	6002	561.5	18	75
217	G<6>	5981	681.5	18	75
218	G<8>	5960	561.5	18	75
219	G<10>	5939	681.5	18	75
220	G<12>	5918	561.5	18	75
221	G<14>	5897	681.5	18	75
222	G<16>	5876	561.5	18	75
223	G<18>	5855	681.5	18	75
224	G<20>	5834	561.5	18	75
225	G<22>	5813	681.5	18	75
226	G<24>	5792	561.5	18	75
227	G<26>	5771	681.5	18	75
228	G<28>	5750	561.5	18	75
229	G<30>	5729	681.5	18	75
230	G<32>	5708	561.5	18	75
231	G<34>	5687	681.5	18	75
232	G<36>	5666	561.5	18	75
233	G<38>	5645	681.5	18	75
234	G<40>	5624	561.5	18	75
235	G<42>	5603	681.5	18	75
236	G<44>	5582	561.5	18	75

No.	Name	X	Y	W	H
237	G<46>	5561	681.5	18	75
238	G<48>	5540	561.5	18	75
239	G<50>	5519	681.5	18	75
240	G<52>	5498	561.5	18	75
241	G<54>	5477	681.5	18	75
242	G<56>	5456	561.5	18	75
243	G<58>	5435	681.5	18	75
244	G<60>	5414	561.5	18	75
245	G<62>	5393	681.5	18	75
246	G<64>	5372	561.5	18	75
247	G<66>	5351	681.5	18	75
248	G<68>	5330	561.5	18	75
249	G<70>	5309	681.5	18	75
250	G<72>	5288	561.5	18	75
251	G<74>	5267	681.5	18	75
252	G<76>	5246	561.5	18	75
253	G<78>	5225	681.5	18	75
254	G<80>	5204	561.5	18	75
255	G<82>	5183	681.5	18	75
256	G<84>	5162	561.5	18	75
257	G<86>	5141	681.5	18	75
258	G<88>	5120	561.5	18	75
259	G<90>	5099	681.5	18	75
260	G<92>	5078	561.5	18	75
261	G<94>	5057	681.5	18	75
262	G<96>	5036	561.5	18	75
263	G<98>	5015	681.5	18	75
264	G<100>	4994	561.5	18	75
265	G<102>	4973	681.5	18	75
266	G<104>	4952	561.5	18	75
267	G<106>	4931	681.5	18	75
268	G<108>	4910	561.5	18	75
269	G<110>	4889	681.5	18	75
270	G<112>	4868	561.5	18	75
271	G<114>	4847	681.5	18	75
272	G<116>	4826	561.5	18	75
273	G<118>	4805	681.5	18	75
274	G<120>	4784	561.5	18	75
275	G<122>	4763	681.5	18	75
276	G<124>	4742	561.5	18	75
277	G<126>	4721	681.5	18	75
278	G<128>	4700	561.5	18	75
279	G<130>	4679	681.5	18	75
280	G<132>	4658	561.5	18	75
281	G<134>	4637	681.5	18	75
282	G<136>	4616	561.5	18	75
283	G<138>	4595	681.5	18	75
284	G<140>	4574	561.5	18	75
285	G<142>	4553	681.5	18	75
286	G<144>	4532	561.5	18	75
287	G<146>	4511	681.5	18	75
288	G<148>	4490	561.5	18	75
289	G<150>	4469	681.5	18	75
290	G<152>	4448	561.5	18	75
291	G<154>	4427	681.5	18	75
292	G<156>	4406	561.5	18	75
293	G<158>	4385	681.5	18	75
294	G<160>	4364	561.5	18	75
295	G<162>	4343	681.5	18	75
296	G<164>	4322	561.5	18	75

No.	Name	X	Y	W	H
297	G<166>	4301	681.5	18	75
298	G<168>	4280	561.5	18	75
299	G<170>	4259	681.5	18	75
300	G<172>	4238	561.5	18	75
301	G<174>	4217	681.5	18	75
302	G<176>	4196	561.5	18	75
303	G<178>	4175	681.5	18	75
304	G<180>	4154	561.5	18	75
305	G<182>	4133	681.5	18	75
306	G<184>	4112	561.5	18	75
307	G<186>	4091	681.5	18	75
308	G<188>	4070	561.5	18	75
309	G<190>	4049	681.5	18	75
310	G<192>	4028	561.5	18	75
311	G<194>	4007	681.5	18	75
312	G<196>	3986	561.5	18	75
313	G<198>	3965	681.5	18	75
314	G<200>	3944	561.5	18	75
315	G<202>	3923	681.5	18	75
316	G<204>	3902	561.5	18	75
317	G<206>	3881	681.5	18	75
318	G<208>	3860	561.5	18	75
319	G<210>	3839	681.5	18	75
320	G<212>	3818	561.5	18	75
321	G<214>	3797	681.5	18	75
322	G<216>	3776	561.5	18	75
323	G<218>	3755	681.5	18	75
324	G<220>	3734	561.5	18	75
325	G<222>	3713	681.5	18	75
326	G<224>	3692	561.5	18	75
327	G<226>	3671	681.5	18	75
328	G<228>	3650	561.5	18	75
329	G<230>	3629	681.5	18	75
330	G<232>	3608	561.5	18	75
331	G<234>	3587	681.5	18	75
332	G<236>	3566	561.5	18	75
333	G<238>	3545	681.5	18	75
334	G<240>	3524	561.5	18	75
335	G<242>	3503	681.5	18	75
336	G<244>	3482	561.5	18	75
337	G<246>	3461	681.5	18	75
338	G<248>	3440	561.5	18	75
339	G<250>	3419	681.5	18	75
340	G<252>	3398	561.5	18	75
341	G<254>	3377	681.5	18	75
342	G<256>	3356	561.5	18	75
343	G<258>	3335	681.5	18	75
344	G<260>	3314	561.5	18	75
345	G<262>	3293	681.5	18	75
346	G<264>	3272	561.5	18	75
347	G<266>	3251	681.5	18	75
348	G<268>	3230	561.5	18	75
349	G<270>	3209	681.5	18	75
350	G<272>	3188	561.5	18	75
351	G<274>	3167	681.5	18	75
352	G<276>	3146	561.5	18	75
353	G<278>	3125	681.5	18	75
354	G<280>	3104	561.5	18	75
355	G<282>	3083	681.5	18	75
356	G<284>	3062	561.5	18	75

No.	Name	X	Y	W	H
357	G<286>	3041	681.5	18	75
358	G<288>	3020	561.5	18	75
359	G<290>	2999	681.5	18	75
360	G<292>	2978	561.5	18	75
361	G<294>	2957	681.5	18	75
362	G<296>	2936	561.5	18	75
363	G<298>	2915	681.5	18	75
364	NC	2893	561.5	18	75
365	NC	2871	681.5	18	75
366	NC	2849	561.5	18	75
367	NC	2827	681.5	18	75
368	NC	2805	561.5	18	75
369	NC	2783	681.5	18	75
370	NC	2761	561.5	18	75
371	NC	2739	681.5	18	75
372	NC	2717	561.5	18	75
373	NC	2695	681.5	18	75
374	NC	2673	561.5	18	75
375	NC	2343	681.5	18	75
376	NC	2321	561.5	18	75
377	VBD<1>	2299	681.5	18	75
378	S<0>	2277	561.5	18	75
379	S<1>	2255	681.5	18	75
380	S<2>	2233	561.5	18	75
381	S<3>	2211	681.5	18	75
382	S<4>	2189	561.5	18	75
383	S<5>	2167	681.5	18	75
384	S<6>	2145	561.5	18	75
385	S<7>	2123	681.5	18	75
386	S<8>	2101	561.5	18	75
387	S<9>	2079	681.5	18	75
388	S<10>	2057	561.5	18	75
389	S<11>	2035	681.5	18	75
390	S<12>	2013	561.5	18	75
391	S<13>	1991	681.5	18	75
392	S<14>	1969	561.5	18	75
393	S<15>	1947	681.5	18	75
394	S<16>	1925	561.5	18	75
395	S<17>	1903	681.5	18	75
396	S<18>	1881	561.5	18	75
397	S<19>	1859	681.5	18	75
398	S<20>	1837	561.5	18	75
399	S<21>	1815	681.5	18	75
400	S<22>	1793	561.5	18	75
401	S<23>	1771	681.5	18	75
402	S<24>	1749	561.5	18	75
403	S<25>	1727	681.5	18	75
404	S<26>	1705	561.5	18	75
405	S<27>	1683	681.5	18	75
406	S<28>	1661	561.5	18	75
407	S<29>	1639	681.5	18	75
408	S<30>	1617	561.5	18	75
409	S<31>	1595	681.5	18	75
410	S<32>	1573	561.5	18	75
411	S<33>	1551	681.5	18	75
412	S<34>	1529	561.5	18	75
413	S<35>	1507	681.5	18	75
414	S<36>	1485	561.5	18	75
415	S<37>	1463	681.5	18	75
416	S<38>	1441	561.5	18	75

No.	Name	X	Y	W	H
417	S<39>	1419	681.5	18	75
418	S<40>	1397	561.5	18	75
419	S<41>	1375	681.5	18	75
420	S<42>	1353	561.5	18	75
421	S<43>	1331	681.5	18	75
422	S<44>	1309	561.5	18	75
423	S<45>	1287	681.5	18	75
424	S<46>	1265	561.5	18	75
425	S<47>	1243	681.5	18	75
426	S<48>	1221	561.5	18	75
427	S<49>	1199	681.5	18	75
428	S<50>	1177	561.5	18	75
429	S<51>	1155	681.5	18	75
430	S<52>	1133	561.5	18	75
431	S<53>	1111	681.5	18	75
432	S<54>	1089	561.5	18	75
433	S<55>	1067	681.5	18	75
434	S<56>	1045	561.5	18	75
435	S<57>	1023	681.5	18	75
436	S<58>	1001	561.5	18	75
437	S<59>	979	681.5	18	75
438	S<60>	957	561.5	18	75
439	S<61>	935	681.5	18	75
440	S<62>	913	561.5	18	75
441	S<63>	891	681.5	18	75
442	S<64>	869	561.5	18	75
443	S<65>	847	681.5	18	75
444	S<66>	825	561.5	18	75
445	S<67>	803	681.5	18	75
446	S<68>	781	561.5	18	75
447	S<69>	759	681.5	18	75
448	S<70>	737	561.5	18	75
449	S<71>	715	681.5	18	75
450	S<72>	693	561.5	18	75
451	S<73>	671	681.5	18	75
452	S<74>	649	561.5	18	75
453	S<75>	627	681.5	18	75
454	S<76>	605	561.5	18	75
455	S<77>	583	681.5	18	75
456	S<78>	561	561.5	18	75
457	S<79>	539	681.5	18	75
458	S<80>	517	561.5	18	75
459	S<81>	495	681.5	18	75
460	S<82>	473	561.5	18	75
461	S<83>	451	681.5	18	75
462	S<84>	429	561.5	18	75
463	S<85>	407	681.5	18	75
464	S<86>	385	561.5	18	75
465	S<87>	363	681.5	18	75
466	S<88>	341	561.5	18	75
467	S<89>	319	681.5	18	75
468	S<90>	297	561.5	18	75
469	S<91>	275	681.5	18	75
470	S<92>	253	561.5	18	75
471	S<93>	231	681.5	18	75
472	S<94>	209	561.5	18	75
473	S<95>	187	681.5	18	75
474	S<96>	165	561.5	18	75
475	S<97>	143	681.5	18	75
476	S<98>	121	561.5	18	75

No.	Name	X	Y	W	H
477	S<99>	99	681.5	18	75
478	S<100>	77	561.5	18	75
479	S<101>	55	681.5	18	75
480	S<102>	33	561.5	18	75
481	S<103>	11	681.5	18	75
482	S<104>	-11	561.5	18	75
483	S<105>	-33	681.5	18	75
484	S<106>	-55	561.5	18	75
485	S<107>	-77	681.5	18	75
486	S<108>	-99	561.5	18	75
487	S<109>	-121	681.5	18	75
488	S<110>	-143	561.5	18	75
489	S<111>	-165	681.5	18	75
490	S<112>	-187	561.5	18	75
491	S<113>	-209	681.5	18	75
492	S<114>	-231	561.5	18	75
493	S<115>	-253	681.5	18	75
494	S<116>	-275	561.5	18	75
495	S<117>	-297	681.5	18	75
496	S<118>	-319	561.5	18	75
497	S<119>	-341	681.5	18	75
498	S<120>	-363	561.5	18	75
499	S<121>	-385	681.5	18	75
500	S<122>	-407	561.5	18	75
501	S<123>	-429	681.5	18	75
502	S<124>	-451	561.5	18	75
503	S<125>	-473	681.5	18	75
504	S<126>	-495	561.5	18	75
505	S<127>	-517	681.5	18	75
506	S<128>	-539	561.5	18	75
507	S<129>	-561	681.5	18	75
508	S<130>	-583	561.5	18	75
509	S<131>	-605	681.5	18	75
510	S<132>	-627	561.5	18	75
511	S<133>	-649	681.5	18	75
512	S<134>	-671	561.5	18	75
513	S<135>	-693	681.5	18	75
514	S<136>	-715	561.5	18	75
515	S<137>	-737	681.5	18	75
516	S<138>	-759	561.5	18	75
517	S<139>	-781	681.5	18	75
518	S<140>	-803	561.5	18	75
519	S<141>	-825	681.5	18	75
520	S<142>	-847	561.5	18	75
521	S<143>	-869	681.5	18	75
522	S<144>	-891	561.5	18	75
523	S<145>	-913	681.5	18	75
524	S<146>	-935	561.5	18	75
525	S<147>	-957	681.5	18	75
526	S<148>	-979	561.5	18	75
527	S<149>	-1001	681.5	18	75
528	S<150>	-1023	561.5	18	75
529	S<151>	-1045	681.5	18	75
530	S<152>	-1067	561.5	18	75
531	S<153>	-1089	681.5	18	75
532	S<154>	-1111	561.5	18	75
533	S<155>	-1133	681.5	18	75
534	S<156>	-1155	561.5	18	75
535	S<157>	-1177	681.5	18	75
536	S<158>	-1199	561.5	18	75

No.	Name	X	Y	W	H
537	S<159>	-1221	681.5	18	75
538	S<160>	-1243	561.5	18	75
539	S<161>	-1265	681.5	18	75
540	S<162>	-1287	561.5	18	75
541	S<163>	-1309	681.5	18	75
542	S<164>	-1331	561.5	18	75
543	S<165>	-1353	681.5	18	75
544	S<166>	-1375	561.5	18	75
545	S<167>	-1397	681.5	18	75
546	S<168>	-1419	561.5	18	75
547	S<169>	-1441	681.5	18	75
548	S<170>	-1463	561.5	18	75
549	S<171>	-1485	681.5	18	75
550	S<172>	-1507	561.5	18	75
551	S<173>	-1529	681.5	18	75
552	S<174>	-1551	561.5	18	75
553	S<175>	-1573	681.5	18	75
554	S<176>	-1595	561.5	18	75
555	S<177>	-1617	681.5	18	75
556	S<178>	-1639	561.5	18	75
557	S<179>	-1661	681.5	18	75
558	S<180>	-1683	561.5	18	75
559	S<181>	-1705	681.5	18	75
560	S<182>	-1727	561.5	18	75
561	S<183>	-1749	681.5	18	75
562	S<184>	-1771	561.5	18	75
563	S<185>	-1793	681.5	18	75
564	S<186>	-1815	561.5	18	75
565	S<187>	-1837	681.5	18	75
566	S<188>	-1859	561.5	18	75
567	S<189>	-1881	681.5	18	75
568	S<190>	-1903	561.5	18	75
569	S<191>	-1925	681.5	18	75
570	S<192>	-1947	561.5	18	75
571	S<193>	-1969	681.5	18	75
572	S<194>	-1991	561.5	18	75
573	S<195>	-2013	681.5	18	75
574	S<196>	-2035	561.5	18	75
575	S<197>	-2057	681.5	18	75
576	S<198>	-2079	561.5	18	75
577	S<199>	-2101	681.5	18	75
578	VBD<2>	-2123	561.5	18	75
579	NC	-2145	681.5	18	75
580	NC	-2167	561.5	18	75
581	NC	-2673	681.5	18	75
582	NC	-2695	561.5	18	75
583	NC	-2717	681.5	18	75
584	NC	-2739	561.5	18	75
585	NC	-2761	681.5	18	75
586	NC	-2783	561.5	18	75
587	NC	-2805	681.5	18	75
588	NC	-2827	561.5	18	75
589	NC	-2849	681.5	18	75
590	NC	-2871	561.5	18	75
591	NC	-2893	681.5	18	75
592	G<299>	-2915	561.5	18	75
593	G<297>	-2936	681.5	18	75
594	G<295>	-2957	561.5	18	75
595	G<293>	-2978	681.5	18	75
596	G<291>	-2999	561.5	18	75

No.	Name	X	Y	W	H
597	G<289>	-3020	681.5	18	75
598	G<287>	-3041	561.5	18	75
599	G<285>	-3062	681.5	18	75
600	G<283>	-3083	561.5	18	75
601	G<281>	-3104	681.5	18	75
602	G<279>	-3125	561.5	18	75
603	G<277>	-3146	681.5	18	75
604	G<275>	-3167	561.5	18	75
605	G<273>	-3188	681.5	18	75
606	G<271>	-3209	561.5	18	75
607	G<269>	-3230	681.5	18	75
608	G<267>	-3251	561.5	18	75
609	G<265>	-3272	681.5	18	75
610	G<263>	-3293	561.5	18	75
611	G<261>	-3314	681.5	18	75
612	G<259>	-3335	561.5	18	75
613	G<257>	-3356	681.5	18	75
614	G<255>	-3377	561.5	18	75
615	G<253>	-3398	681.5	18	75
616	G<251>	-3419	561.5	18	75
617	G<249>	-3440	681.5	18	75
618	G<247>	-3461	561.5	18	75
619	G<245>	-3482	681.5	18	75
620	G<243>	-3503	561.5	18	75
621	G<241>	-3524	681.5	18	75
622	G<239>	-3545	561.5	18	75
623	G<237>	-3566	681.5	18	75
624	G<235>	-3587	561.5	18	75
625	G<233>	-3608	681.5	18	75
626	G<231>	-3629	561.5	18	75
627	G<229>	-3650	681.5	18	75
628	G<227>	-3671	561.5	18	75
629	G<225>	-3692	681.5	18	75
630	G<223>	-3713	561.5	18	75
631	G<221>	-3734	681.5	18	75
632	G<219>	-3755	561.5	18	75
633	G<217>	-3776	681.5	18	75
634	G<215>	-3797	561.5	18	75
635	G<213>	-3818	681.5	18	75
636	G<211>	-3839	561.5	18	75
637	G<209>	-3860	681.5	18	75
638	G<207>	-3881	561.5	18	75
639	G<205>	-3902	681.5	18	75
640	G<203>	-3923	561.5	18	75
641	G<201>	-3944	681.5	18	75
642	G<199>	-3965	561.5	18	75
643	G<197>	-3986	681.5	18	75
644	G<195>	-4007	561.5	18	75
645	G<193>	-4028	681.5	18	75
646	G<191>	-4049	561.5	18	75
647	G<189>	-4070	681.5	18	75
648	G<187>	-4091	561.5	18	75
649	G<185>	-4112	681.5	18	75
650	G<183>	-4133	561.5	18	75
651	G<181>	-4154	681.5	18	75
652	G<179>	-4175	561.5	18	75
653	G<177>	-4196	681.5	18	75
654	G<175>	-4217	561.5	18	75
655	G<173>	-4238	681.5	18	75
656	G<171>	-4259	561.5	18	75

No.	Name	X	Y	W	H
657	G<169>	-4280	681.5	18	75
658	G<167>	-4301	561.5	18	75
659	G<165>	-4322	681.5	18	75
660	G<163>	-4343	561.5	18	75
661	G<161>	-4364	681.5	18	75
662	G<159>	-4385	561.5	18	75
663	G<157>	-4406	681.5	18	75
664	G<155>	-4427	561.5	18	75
665	G<153>	-4448	681.5	18	75
666	G<151>	-4469	561.5	18	75
667	G<149>	-4490	681.5	18	75
668	G<147>	-4511	561.5	18	75
669	G<145>	-4532	681.5	18	75
670	G<143>	-4553	561.5	18	75
671	G<141>	-4574	681.5	18	75
672	G<139>	-4595	561.5	18	75
673	G<137>	-4616	681.5	18	75
674	G<135>	-4637	561.5	18	75
675	G<133>	-4658	681.5	18	75
676	G<131>	-4679	561.5	18	75
677	G<129>	-4700	681.5	18	75
678	G<127>	-4721	561.5	18	75
679	G<125>	-4742	681.5	18	75
680	G<123>	-4763	561.5	18	75
681	G<121>	-4784	681.5	18	75
682	G<119>	-4805	561.5	18	75
683	G<117>	-4826	681.5	18	75
684	G<115>	-4847	561.5	18	75
685	G<113>	-4868	681.5	18	75
686	G<111>	-4889	561.5	18	75
687	G<109>	-4910	681.5	18	75
688	G<107>	-4931	561.5	18	75
689	G<105>	-4952	681.5	18	75
690	G<103>	-4973	561.5	18	75
691	G<101>	-4994	681.5	18	75
692	G<99>	-5015	561.5	18	75
693	G<97>	-5036	681.5	18	75
694	G<95>	-5057	561.5	18	75
695	G<93>	-5078	681.5	18	75
696	G<91>	-5099	561.5	18	75
697	G<89>	-5120	681.5	18	75
698	G<87>	-5141	561.5	18	75
699	G<85>	-5162	681.5	18	75
700	G<83>	-5183	561.5	18	75
701	G<81>	-5204	681.5	18	75
702	G<79>	-5225	561.5	18	75
703	G<77>	-5246	681.5	18	75
704	G<75>	-5267	561.5	18	75
705	G<73>	-5288	681.5	18	75
706	G<71>	-5309	561.5	18	75
707	G<69>	-5330	681.5	18	75
708	G<67>	-5351	561.5	18	75
709	G<65>	-5372	681.5	18	75
710	G<63>	-5393	561.5	18	75
711	G<61>	-5414	681.5	18	75
712	G<59>	-5435	561.5	18	75
713	G<57>	-5456	681.5	18	75
714	G<55>	-5477	561.5	18	75
715	G<53>	-5498	681.5	18	75
716	G<51>	-5519	561.5	18	75

No.	Name	X	Y	W	H
717	G<49>	-5540	681.5	18	75
718	G<47>	-5561	561.5	18	75
719	G<45>	-5582	681.5	18	75
720	G<43>	-5603	561.5	18	75
721	G<41>	-5624	681.5	18	75
722	G<39>	-5645	561.5	18	75
723	G<37>	-5666	681.5	18	75
724	G<35>	-5687	561.5	18	75
725	G<33>	-5708	681.5	18	75
726	G<31>	-5729	561.5	18	75
727	G<29>	-5750	681.5	18	75
728	G<27>	-5771	561.5	18	75
729	G<25>	-5792	681.5	18	75
730	G<23>	-5813	561.5	18	75
731	G<21>	-5834	681.5	18	75
732	G<19>	-5855	561.5	18	75

No.	Name	X	Y	W	H
733	G<17>	-5876	681.5	18	75
734	G<15>	-5897	561.5	18	75
735	G<13>	-5918	681.5	18	75
736	G<11>	-5939	561.5	18	75
737	G<9>	-5960	681.5	18	75
738	G<7>	-5981	561.5	18	75
739	G<5>	-6002	681.5	18	75
740	G<3>	-6023	561.5	18	75
741	G<1>	-6044	681.5	18	75
742	NC	-6065	561.5	18	75
743	NC	-6086	681.5	18	75
744	NC	-6107	561.5	18	75
745	NC	-6128	681.5	18	75
746	NC	-6149	561.5	18	75
747	NC	-6170	681.5	18	75

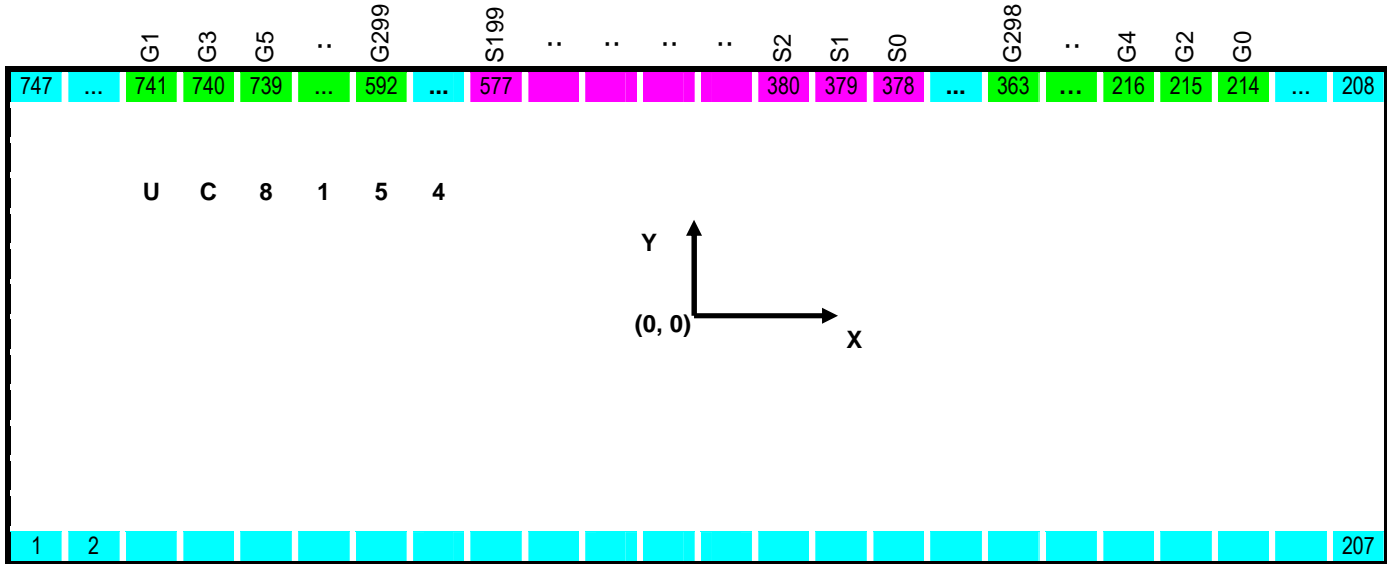

TRAY INFORMATION

